

NEW
DAILY
4x4

BODYBUILDERS
INSTRUCTIONS



LIGHT RANGE

IVECO

ISSUE 2015

IVECO S.p.A
Homologation, Technical Application & Regulation
Lungo Stura Lazio, 49
10156 Torino (TO) - Italy

www.iveco.com

Printed **603.95.994** – 1st ed. 05/2015

Images and text: IVECO S.p.A. 2014
All rights reserved.

UPDATE DATA

Section	Description	Page	Revision date

INTRODUCTION

This publication provides information, features and instructions for transformation and fitting of the vehicle; considering the type of content, it is meant for qualities and specialised staff.

The Body builder is manager of the project and its execution, and must assure compliance with what is set forth in this publication and in the laws in forth.

Any modification, transformation or fitting not described in this manual and not expressly authorized will relieve IVECO of any liability and the warranty, if present, will immediately be null and void.

The same applies to individual assemblies and components; those described in this manual have been deliberated, approved and tested by IVECO and are part of normal production. The use of any type of unit not recognised (such as PTO, tyres, horns, etc.) relieves IVECO from any liability.

IVECO is available to provide information on the implementation of the interventions and to provide instructions for any cases and situations not covered in this publication.

Before performing any operation, it is necessary to:





- verify that you have the manuals for the vehicle model on which you are about to work;
- ensure that all the safety devices (goggles, helmet, gloves, shoes, etc.), as well as the equipment used for work, lifting and transport, is available and working;
- ensure that the vehicle is placed in safe conditions.

At the end of the operation, the operational, efficiency and safety conditions set by IVECO must be restored. Contact the Service network for vehicle calibration if necessary.

Data and information contained in this publication may be outdated as a result of changes adopted by IVECO, at any time, for technical or commercial reasons or due to the need to adapt the vehicle to new legal requirements.

In the event of discordance between the information herein and the actual vehicle, please contact the Product Manager operating on the market before performing any interventions.

SYMBOLS - WARNINGS

	Danger for persons Failure to comply with these prescriptions can result in the risk of serious injury.
	Risk of serious damage to the vehicle Partial or complete non observance of these prescriptions can lead to serious damages to the vehicle and can sometimes result in the guarantee being voided.
	General danger Includes the dangers of both above described signals.
	Environmental protection Indicates correct behaviour in order that vehicle use is as environmentally friendly as possible.
NOTE	Indicates an additional explanation for a piece of information.

GENERAL INFORMATION	1
CHASSIS INTERVENTIONS	2
APPLICATIONS OF SUPERSTRUCTURES	3
POWER TAKE-OFFS	4
ELECTRONIC SUB-SYSTEMS	5
ADBLUE AND SCRT SYSTEM	6

SECTION 1
**GENERAL
INFORMATION**

Contents

I.1	SCOPE OF THE GUIDELINES	5
I.2	TECHNICAL DOCUMENTATION AVAILABLE ELECTRONICALLY	5
I.3	IVECO AUTHORISATION	5
I.4	AUTHORISATION REQUEST	6
I.5	RESPONSIBILITIES	6
I.6	LEGISLATIVE REQUIREMENTS	6
I.7	MULTI-STAGE APPROVAL - COLLABORATION (only for EU countries, Switzerland and Turkey)	6
I.8	GUARANTEES	7
I.9	QUALITY SYSTEM MANAGEMENT	8
I.10	ACCIDENT PREVENTION	8
I.11	CHOICE OF MATERIALS TO USE: ECOLOGY - RECYCLING	8
I.12	VEHICLE MANAGEMENT ON THE PART OF BODYBUILDER	9
	Acceptance of chassis	9
	Maintenance	9
	Delivery of the vehicle to the final customer	9
I.13	VEHICLE NAMES	10
	Type approval name	10
I.14	IDENTIFICATIONS	10
I.15	DIMENSIONS AND GROUND	11
	General information	11
	Determination of the centre of gravity of the superstructure and the payload	12
	Respect of the permitted masses	15
I.16	INSTRUCTIONS FOR PROPER FUNCTIONING OF THE VEHICLE PARTS AND ACCESSIBILITY	15
I.17	GENERAL REGULATION FOR THE PREVENTION OF FIRE RISK	16
I.18	CONVENTIONS	16

GENERAL INFORMATION

I.1 SCOPE OF THE GUIDELINES

The scope of this publication is to provide information, features and instructions for fitting and transformation of the original IVECO vehicle in order to ensure its functionality, safety and reliability.

These Guidelines also aim to indicate to Bodybuilders:

- the quality level to be obtained;
- obligations regarding the safety of operations;
- obligations regarding the objective responsibility of the product.

It should be noted that the collaboration with IVECO is based on the assumption that the Bodybuilder uses the maximum of their technical and organisational skills and that operations are technically and perfectly complete. As outlined below, the topic is extensive and we can only provide the rules and minimum precautions that can allow development of the technical initiative.

Faults or defects caused by total or partial failure to comply with these Guidelines are not covered by the guarantee on the chassis or relative mechanical units.

I.2 TECHNICAL DOCUMENTATION AVAILABLE ELECTRONICALLY

On the website www.ibb.iveco.com the following technical documentation is available:

- Guidelines for transformation and fitting of vehicles;
- technical specifications;
- truck diagrams;
- tractor diagrams;
- chassis diagrams;
- other range-specific data.

Requests to access the site must be made exclusively at www.ibb.iveco.com.

I.3 IVECO AUTHORISATION

Modifications or fittings proved in these Guidelines and carried out in respect of the same do not require a specific authorisation.

On the other hand, IVECO authorisation is required to carry out:

- particular changes to the wheelbase;
- work on the braking system;
- modifications to the steering system;
- modifications to the stabiliser bars and suspensions;
- modifications to the cab, cab mounts, locking and tilting devices;
- modifications to intake, engine exhaust and SCR components;
- applications of retarders;
- power take-off applications;
- variations in tyre measurements;
- modifications to hook organisms (hooks, fifth wheels).

I.4 AUTHORISATION REQUEST

Authorisation requests, when necessary, must be sent to the responsible IVECO Departments on the market.

The Bodybuilder must provide vehicle data (cab, wheelbase, overhang, chassis No.) and adequate documentation (drawings, calculations, technical report, etc.) showing the realisation, use and operating conditions of the vehicle. The drawings should evidence everything that differs from these instructions.

Upon completion of the interventions the bodybuilder shall be responsible for attainment of definitive approval from the competent authority.

I.5 RESPONSIBILITIES

The authorisations issued by IVECO are exclusively related to the technical/conceptual feasibility of the modification and/or fitting.

The Bodybuilder is therefore responsible for:

- the design;
- the choice of materials;
- the implementation;
- the compliance of the design and implementation to any specific indications provided by IVECO and the laws in force in the countries where the vehicle is destined;
- effects on functionality, safety, reliability and, in general, good behaviour of the vehicle;
- the supply of spare parts for a minimum period of 10 years starting from the last fitting of an order and for all pieces and components that are installed.

I.6 LEGISLATIVE REQUIREMENTS

The Bodybuilder must verify that the final product is compliant, without exception, to all applicable legal requirements, on the municipal/autonomous/national level of each State in which it is registered and/or will circulate (Highway code, Official Regulations, etc.) and on the international level (European Union Directives, ONU/Geneva ECE Regulations, etc.). It is also necessary to comply with all requirements for accident prevention, instructions for assistance, the environment, etc.

The regulations on accident prevention or the legal indications cited in these Guidelines may be considered the most important, but are not meant in any way to replace or eliminate the obligation and responsibility of the Bodybuilder to stay properly informed.

For this reason, IVECO shall not be held liable for any consequences due to errors caused by insufficient knowledge or incorrect interpretation of the legal provisions in force.

I.7 MULTI-STAGE APPROVAL - COLLABORATION (only for EU countries, Switzerland and Turkey)

Attachment XVII of Directive 2007/46/EC concerns *Multi-stage approval*.

This procedure requires that each manufacturer is responsible for the approval and compliance of the production of systems, components and "separate technical units" produced by the same or applied to the vehicle.

The manufacturer of the vehicle is defined as *first-stage manufacturer*, while the bodybuilder is defined as *Second-stage manufacturer* or that of the next stage.

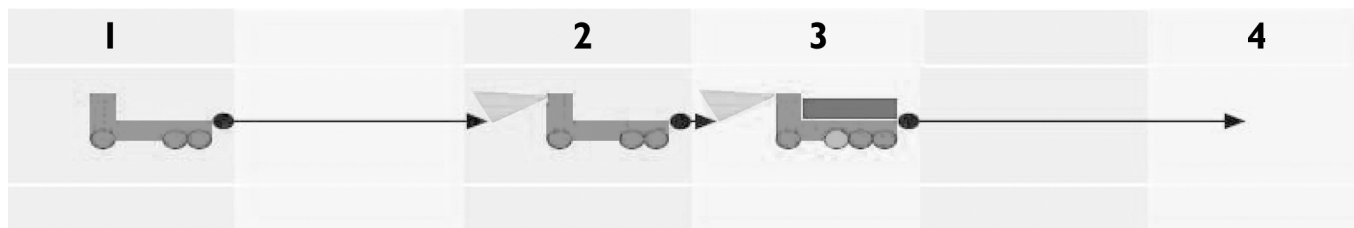

191319

Figure 1

- | | |
|--|----------------|
| 1. IVECO | 3. Bodybuilder |
| 2. Authorised workshop upon Dealer order | 4. Customer |

Based on this Directive, IVECO (main vehicle manufacturer) and a Bodybuilder intending to launch the multi-stage approval process must sign a specific Collaboration Contract, called *Technical Agreement*, which sets out the content and reciprocal obligations in detail.

Consequently:

1. IVECO has the responsibility of providing, in the agreed form, the approval documents (EC/ECE approvals) and the technical information necessary for the proper implementation of the fitting and/or transformation (manuals, drawings, specifications);
2. the Bodybuilder has the following responsibilities:
 - the design and implementation of modifications to the basic vehicle received from IVECO,
 - reattainment of approvals of systems already approved in a previous stage when, due to changes on the basic vehicle the approvals need to be updated,
 - compliance with national/international laws and in particular the laws of the destination country, for all changes made,
 - presentation of the changes made to a technical service, for evaluation,
 - appropriate documentation of the changes made, in order to give objective evidence of compliance to the aforementioned provisions of law (e.g. approval documents/test reports).

Before signing the *Technical Agreement* IVECO reserves the right to visit the Bodybuilder, in order to verify qualifications to carry out the fittings and/or processing for which the above collaboration is requested.

The contents of the *Technical Agreement* can be evaluated in detail upon request to the Manager for relations with the Bodybuilder for the single Market.

I.8 GUARANTEES

The guarantee that the work has been performed to standard must be given by the Bodybuilder who made the superstructure or modifications to the chassis, in full compliance with the instructions in these Guidelines.

IVECO reserves the right to void the guarantee on the vehicle, if:

- unauthorised fittings or transformations have been carried out;
- a chassis not suitable for the fitting or intended use has been used;
- the standards, specifications and instructions, provided by IVECO for proper execution of the work, have not been respected;
- original spare parts or components made available by IVECO for specific operations have not been used;
- safety regulations have not been respected;
- the vehicle is used for purposes other than those for which it was designed.

I.9 QUALITY SYSTEM MANAGEMENT

IVECO has always promoted the training and development of a Quality System for Bodybuilders.

This requirement is not only due to regulations on product liability, but also to the increasingly higher quality level demands, new organizational forms in various sectors and the search for more advanced levels of efficiency.

IVECO therefore considers it appropriate for Bodybuilders to be equipped with:

- organizational charts for roles and responsibilities;
- quality objectives and indicators;
- design technical documentation;
- process documentation, including controls;
- plan for product improvement, also obtained through corrective actions;
- post-sales assistance;
- training and qualification of staff.

The availability of ISO 9001 certification, even though not required, is considered very important by IVECO.

I.10 ACCIDENT PREVENTION

Do not allow unauthorised personnel to intervene or operate on the vehicle.

It is forbidden to use the vehicle with safety devices that have been tampered with or are damaged.



- ▶ **Structures and devices installed on the vehicles must comply with the applicable regulations for accident prevention, and with safety regulations required in the individual countries where the vehicles are used.**

All precautions dictated by technical knowledge must be taken to avoid damage and functional defects.

Compliance with these requirements must be overseen by the bodybuilders of the structures and devices.



- ▶ **Seats, coatings, gaskets, protective panels, etc., may pose a fire hazard when exposed to an intense heat source. Remove them before working with welding and with flames.**

I.11 CHOICE OF MATERIALS TO USE: ECOLOGY - RECYCLING

In the study and design phase, the choice of materials to be used by be made carefully, even from the ecological and recycling point of view.

To this regard, please note that:

- it is forbidden to use materials that are harmful to health, or at least which may pose a risk, such as those containing asbestos, lead, halogen additives, fluorocarbons, cadmium, mercury, hexavalent chromium, etc.;
- it is advisable to use materials whose processing produces limited waste quantities and allows easy recycling after first use;
- in synthetic materials of the composite type, it is advisable to use components that are compatible with each other, allowing use with the possible addition of other recovery components. Prepare the required markings in accordance with the regulations in force;
- the batteries contain substances that are very dangerous for the environment. To replace the batteries it is possible to go to the Service Network, equipped for disposal in accordance with the nature and the law.



- ▶ **To comply with Directive 2000/53 EC (ELVs), IVECO prohibits the in-vehicle installation of components that contain lead, mercury, cadmium and hexavalent chromium; exceptions are made in cases allowed by Annex II of the above Directive.**

I.12 VEHICLE MANAGEMENT ON THE PART OF BODYBUILDER

Acceptance of chassis

The Bodybuilder receiving a chassis/vehicle from IVECO or from a Dealer must perform a preliminary check, notifying of any missing accessories or damage attributable to the transporter.

Maintenance

To preserve the chassis/vehicle in its full efficiency, even while parking in the warehouse, maintenance operations may be necessary within a predetermined time.

The expenses for carrying out these operations are borne by the owner of the vehicle in that moment (Bodybuilder, Dealer or Customer).



- ▶ **In case of long periods of vehicle inactivity, it is advisable to disconnect the negative pole of the battery to maintain optimal charging status.**

Delivery of the vehicle to the final customer

Before delivering the vehicle, the Body builder must:

- calibrate its production (vehicle and/or equipment) and verify functionality and safety;
- perform all checks on the Pre-Delivery Inspection (PDI) list available from the IVECO network, for items that will be subjected to repairs and, in particular, check the alignment, toe-in and height of the front suspensions based on the IVECO reference values
- measure battery voltage with a digital multimeter (2 digit decimal), keeping in mind that:
 - optimal value is equal to 12.5 V,
 - between 12.1 V and 12.49 V the battery should be put under a slow charge,
 - with values less than 12.1 V the battery should be replaced.

Note *The batteries must be maintained at regular intervals (refer to IVECO Std 20-1812 and/or IVECO Std 20-1804) until delivery of the vehicle to the Customer/Dealer to avoid problems of insufficient charging, short circuit or corrosion.*

IVECO reserves the right to nullify the guarantee on the battery if the prescribed maintenance procedures are not respected.

- carry out a functional road test (in case of vehicle transformation). Any defects or problems should be notified to the IVECO Assistance Service to verify conditions for inclusion in the PDI costs;
- prepare and deliver to the final Customer the necessary instructions for service and maintenance of the fitting and any added units;
- report new data on special labels;
- provide confirmation that the operations carried out comply with the indications of the vehicle Manufacturer and legal requirements;
- draw up a guarantee covering the changes made.

Instructions for additional units

For additional units, the Body builder must provide all necessary maintenance instructions upon vehicle delivery.

All the units that make up the same order must be equipped with components of the same brand, model and quality.

I.13 VEHICLE NAMES

The commercial name of IVECO vehicles (for example **NEW DAILY 35-170**) does not match the type approval name. A complete example is provided below.

Type approval name

DAILY 35S17H CCS W

- **DAILY** – Vehicle name
- **35** – Gross mass - GVW (no/10 = weight in t)

35	3,5 t
55	5,5 t

- **S** – Rear wheels

S	Single rear wheels
---	--------------------

- **17** – Engine power (no. x 10 = power in HP)

15	146 HP
17	170 HP

- **H** – Engine type

H	Euro VI Engine (combined with engine power codes 17)
E3	Euro III Engine (combined with engine power codes 15)

- **CCS** – Version

–	Cab version
D	Dual cab (6+1)
CCS	Cowl (short)
CA	Cut Away

- **W** – 4x4

I.14 IDENTIFICATIONS

Logos, identification tradenames and nameplates must not be modified, displaced or removed since the original design appearance of the vehicle must be safeguarded.

The application of trademarks relating to the transformation or outfitting must be authorised. They must not be applied near to the IVECO tradenames or logos.

In the event of cowl vehicles, the positioning of the IVECO logo on the engine bonnet must be done only after final paint spraying and must respect the measurements indicated qualitatively in the following figure.

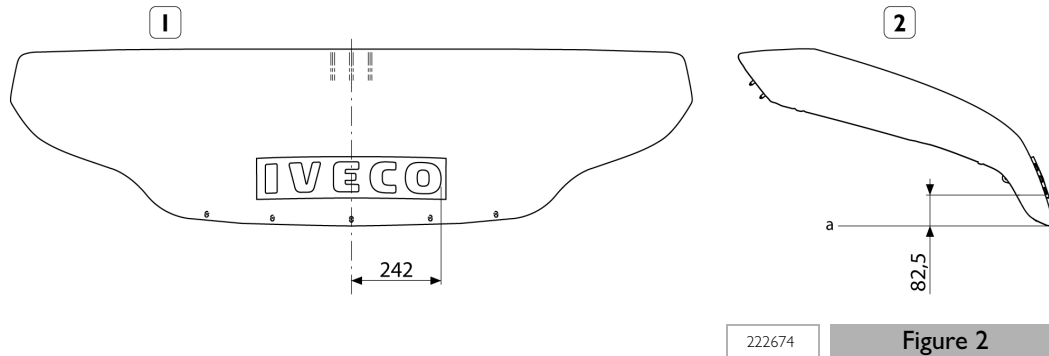

- 1. Front view
- 2. Side view

a. Bonnet lower edge

For the actual measurements and for the realization of a possible template, please consult the design 5801620982.

IVECO reserves the right to withdraw its tradenames and logos if the above requirements are not met.

I.15 DIMENSIONS AND GROUND

General information

The dimensions and masses of vehicles allowed on the axles are shown in the drawings, the technical descriptions and, more generally, on the documents on the official IVECO website. Defects refer to vehicles in their standard versions; the use of special equipment may lead to changes on the masses and their distribution on the axles.

Weighing of the chassis

It should be noted that variations are possible on the masses of the order of 5%.

For this reason, before carrying out the fitting, it is a good idea to determine the mass of the vehicle cab and its distribution on the axles.

Vehicle adaptability

The body length limits mainly depend on:

- wheelbase length
- distribution of mass on the axles
- maximum permitted width.

The maximum permitted width on the Daily MCA is 2550 mm.

Rear-view mirrors

The rear visibility angles imposed by legislation may be respected by choosing, depending on the width of the vehicle version, the most appropriate type of rear-view mirror from the three models with arms of varying width, present in the catalogue (opt. 8643, 8644, 76129).

Determination of the centre of gravity of the superstructure and the payload

To determine the position of the centre of gravity of the superstructure and of the payload, proceed according to the following examples.

The specific technical documentation for each model (cab version diagram) illustrates the positions allowed with the standard version vehicle. The masses and the positioning of the individual components of the vehicle are shown on the chassis and weight allocation diagram.

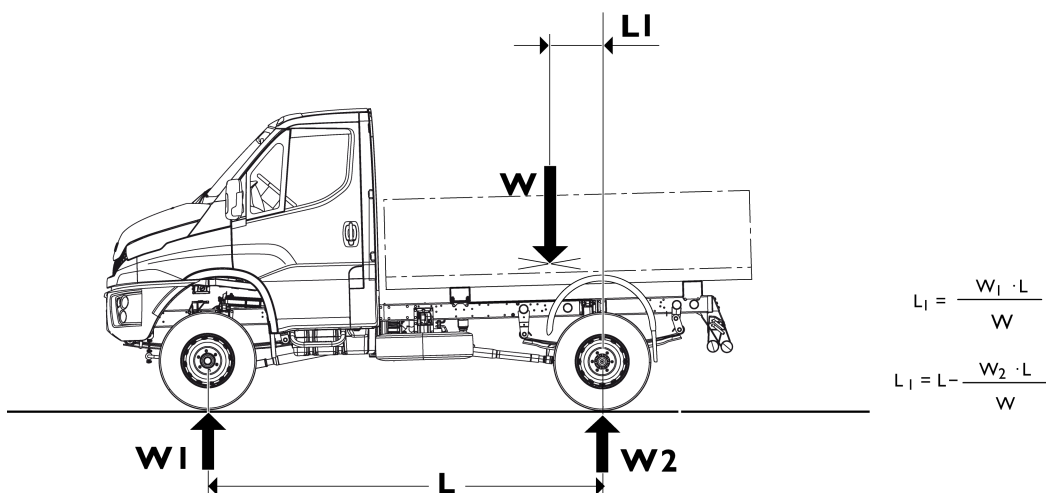

227313

Figure 3

W = Payload plus superstructure

W_1 = Measurement of payload on front axle

W_2 = Measurement of payload on rear axle

L_1 = Distance of centre of gravity from centre line of rear axle

L = Actual wheelbase

For the purposes of payload distribution on the axles, it is assumed that this is evenly distributed, except in cases in which the shape of the load surface results in a different load distribution.

For equipment, the centre of gravity is obvious considered for its actual position.

In the realisation of the superstructure or containers, automatic loading and unloading of the goods transported must be provided to avoid excessive variations of the distribution and/or excessive loads on the axles, providing information for users if necessary.

The Body builder should also provide a suitable anchoring systems for the load on the superstructure, so that transport can occur in maximum security.

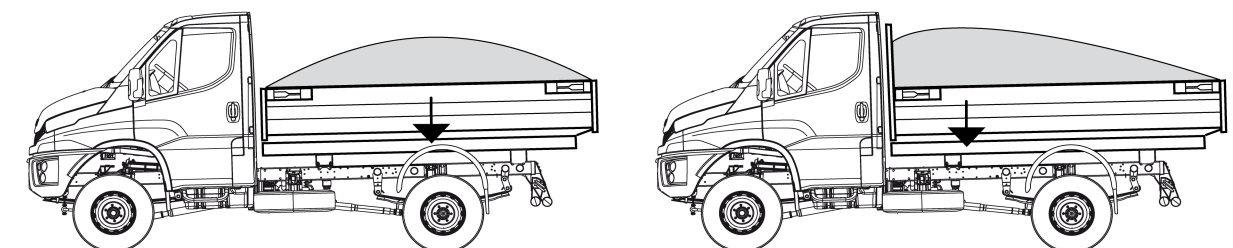

227314

Figure 4

Even distribution of load

Uneven distribution of load

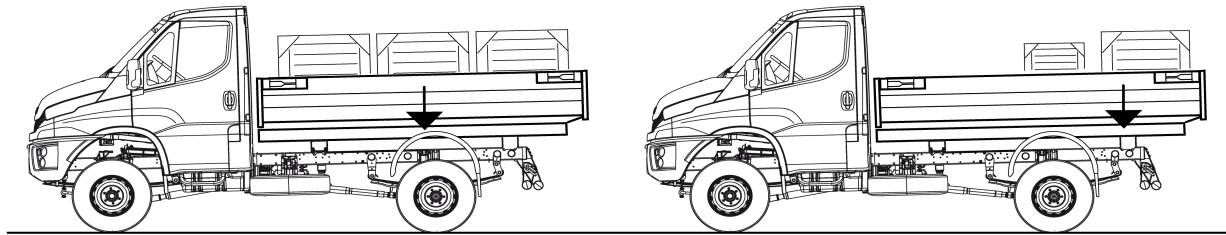

227315

Figure 5

Even distribution of load

Uneven distribution of load (attention to loads on axles and minimum ratio)

Height of centre of gravity

For the cab version and no-load vehicle, the value of the height of the centre of gravity is shown on the specific technical documentation for each model (cab version diagram).

For the vehicle complete with super structure and full load, this height must comply with the maximum values allowed by national or international standards, in particular, Directives ECE 13 on longitudinal stability and ECE 111 on lateral stability while driving.

The following cases should be distinguished:

- fixed loads,
- mobile loads;
- loads that result in increased aerodynamic actions.

a) Fixed loads

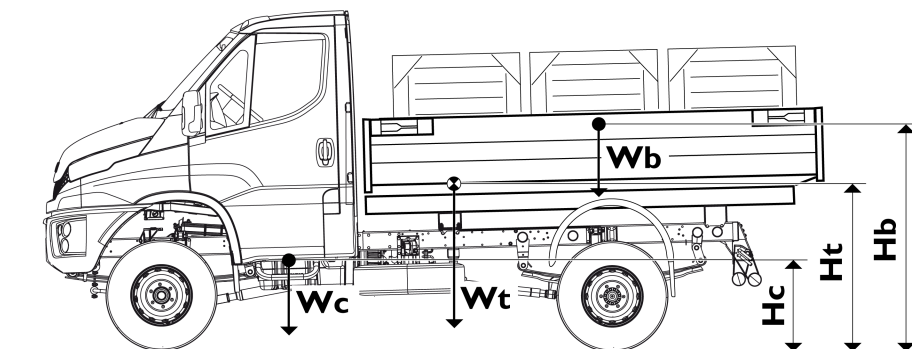

$$H_t = \frac{W_c \cdot H_c + W_b \cdot H_b}{W_c + W_b}$$

$$H_b = \frac{(W_c + W_b) \cdot H_t - W_c \cdot H_c}{W_b}$$

227316

Figure 6

Control at full load

- Hc = Vehicle centre of gravity height (loaded)
- Hb = Height of payload centre of gravity from the ground
- Ht = Complete full-load vehicle centre of gravity height

- Wc = Vehicle tare weight
- Wb = Payload
- Wt = Complete vehicle ground at full load

For any inspections with the vehicle set up without payload you can proceed similarly, assuming Ws is only the tare weight of the superstructure (considering for Hv a value appropriate for the load and between the no-load cab version trim and the full-load trim).

For any inspections of the vehicle set up with payload, the maximum height of the centre of total weight (payload + body and/or equipment), referring to transverse stability is 1590 mm.

b) Mobile loads

In the versions where the load can be moved laterally while cornering (e.g.: suspended loads, liquid transport, animal transport, etc..) high lateral dynamic forces may be generated which may jeopardise the stability of the vehicle.

With reference to the indications of ECE 111, special attention should therefore be paid:

- in defining the height of the fitted vehicle's centre of gravity and at full load;
- in assessing the dynamic forces and the lateral displacement of the centre of gravity;
- in considering (for liquids) the density;
- in prescribing the adoption of adequate precautions for driving.

Any cases where evaluation is difficult should be submitted to IVECO for approval.

c) Loads that result in increased aerodynamic actions

In fittings characterised by high vertical and surface development (e.g.: advertising panelling), the height of the centre of thrust, determined in the case of cross-wind, must be evaluated very carefully.



- ▶ **Even with the low centre of gravity, a vehicle fitting that has a high surface area may not provide sufficient lateral stability and may be exposed to the danger of tilting.**

Special attention must therefore be paid:

- in defining the height of the fitted vehicle's centre of gravity and at full load,
- in assessing the aerodynamic forces,
- in prescribing the adoption of adequate precautions for driving.

Any cases where evaluation is difficult should be submitted to IVECO for approval.

Adoption of stabiliser bars

The application of additional or reinforced stabiliser bars, where available, reinforcing the springs or rubber elastic parts (in accordance with the procedure outlined in Chapter 2.9 (► Page 18)), may allow higher values of the centre of gravity of the payload, to be determined on a case by case basis. The operation must be carried out after careful evaluation of the outfitting characteristics, the wheelbase and the distribution of transverse forces on the suspension, and should generally concern both the front and the rear. However, it should be kept in mind that in many cases it is advisable to carry out the operation only on the rear axle; acting on the front axle would give the driver an incorrect sensation of greater stability, making it actually harder to perceive the safety limit. Interventions on the front axle may be performed in the presence of concentrated loads behind the cab (e.g. cranes) or of superstructures with high rigidity (e.g. vans).

Respect of the permitted masses

All the limits shown on IVECO documentation must be respected. It is particularly important to evaluate the maximum ground on the front axle in any load condition, in order to ensure the necessary steering features in all road surface conditions.

Special attention must therefore be paid to vehicles with concentrated load on the rear overhang (e.g.: cranes, tail lifts, trailers with centre axle) and short wheelbase vehicles and high centre of gravity.

Note *In the positioning of the auxiliary bodies and superstructure, a proper load distribution in the transverse direction must be ensured. A variation on the nominal load may be permitted for each wheel (50% load on the corresponding axle) of $\pm 4\%$ (e.g.: load allowed on the axle 3,000 kg; allowed for each wheel side from 1,440 to 1,560 kg) in compliance with what is permitted by the tyres, without affecting the braking and driving stability characteristics of the vehicle.*

Unless other specific dispositions are provided for individual vehicles, one must consider for the mass on the front axle a minimum value of 25% of the effective mass of the vehicle (with loads distributed uniformly as well as with loads on the rear overhang or associated with a trailer, if attached).

The rear overhang of the superstructure must be implemented in full compliance with the permitted axle loads, the minimum load required on the front axle, length limits, the position of the tow coupling and the under-run protection as envisaged by various standards and regulations.

Variations on permitted masses

Special exemptions from the maximum permissible masses may be granted for specific uses, for which, however, there are precise limits for use and reinforcements to be made to parts of the vehicle.

These exceptions, if they exceed the limits of the law, must be authorised by the Administrative Authority.

In the authorisation request, you must indicate:

- type of vehicle, wheelbase, chassis number, intended use;
- division of the tare weight on the axles (in fitted vehicles, e.g.: crane with flatbed), with the position of the payload centre of gravity;
- any proposals for strengthening the parts of the vehicle.

The permitted reduction of mass on vehicles (derating), can lead to interventions on some parts, such as suspensions and brakes, and may require a new calibration for the braking correction operation; in these cases the necessary indications may be provided.

I.16 INSTRUCTIONS FOR PROPER FUNCTIONING OF THE VEHICLE PARTS AND ACCESSIBILITY

In carrying out the transformations and applying any type of equipment, there should be no alteration to what enables the proper functioning of the vehicle units and parts under various working conditions.

For example:

- free access must be guaranteed to the places that need inspection, maintenance or periodic controls (e.g., battery replacement, access to the air suspension compressor) and, in the case of enclosed superstructures, special compartments and doors should be provided;
- the possibility of disassembling the various groups for assistance operations must be maintained;
- in the fitting that provides the tipping of the lateral tails, consider the size of the most protruding parts of the vehicle, in order to avoid limitations to tipping or damage to the parts.
- conditions should not be affected regarding cooling (radiator grille, radiator, air passages, cooling etc.), fuel supply (pump positioning, filters, pipe diameter, etc.) and engine air intake;
- the soundproofing panels must not be altered or moved so as not to affect the approved sound emission limits. If any openings need to be made (e.g. for the passage of pipes or added sections), they must be thoroughly closed, using fireproof and soundproofing materials equivalent to the original materials used;

- adequate ventilation must be maintained for the brakes and battery casing (particularly in the execution of truck bodies);
- in the placement of fenders and wheel arches, free shaking of the rear wheels must be guaranteed, even under the conditions of use with chains.
- adjustment of the vehicle's headlamps must be checked once construction is completed, to correct any changes in their structure; for adjustment, proceed according to the instructions given in the "Use and Maintenance Handbook";
- for any elements supplied loose (e.g. spare wheel, chocks), the Body builder must position and fasten them in an accessible and secure way, in compliance to any national regulations.

I.17 GENERAL REGULATION FOR THE PREVENTION OF FIRE RISK

Particular attention must be paid to prevent the spillage of hydraulic fluids or inflammable liquids above components which may become hot or overheated.

Therefore, when pipes must be inevitably installed near the engine, exhaust system, catalytic converter or turbocharger, suitable insulating shields or protective plates must be provided.

I.18 CONVENTIONS

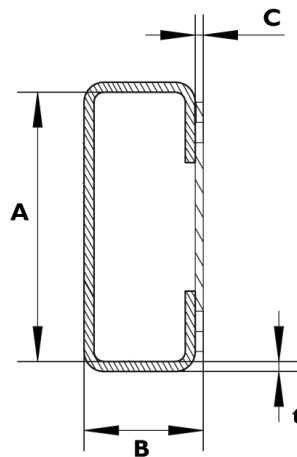

120360

Figure 7

In these Guidelines the following conventions are adopted:

- **Wheelbase:** distance between the centre lines of the first steering axle and the first rear axle (engine or not).
- **Rear overhang:** distance between the centre line of the last axle and the rear extremity of the chassis side members.
- **Dimensions A, B, t and c** of the chassis section: see Figure 7.

SECTION 2
**CHASSIS
INTERVENTIONS**

Contents	
2.1 GENERAL CHASSIS MODIFICATION STANDARDS	5
Preventive measures	5
Characteristics of the material used in chassis modifications	6
Stresses on the chassis	7
2.2 DRILLS ON THE CHASSIS	7
Hole position and size	7
Screws and nuts	8
Sealing holes by welding	8
2.3 RUST AND PAINT PROTECTION	9
Original vehicle parts	9
Added or modified parts	11
Precautions	11
2.4 WHEELBASE MODIFICATION	12
2.5 REAR OVERHANG MODIFICATION	12
2.6 INSTALLING THE TOW HOOK	13
General information	13
Precautions for Installation	13
Drawbar couplings for centre axle trailers	15
2.7 ASSEMBLING AN ADDITIONAL AXLE	17
2.8 GEARBOX MODIFICATION	17
2.9 WORK ON SUSPENSIONS	18
2.10 MODIFYING THE ENGINE AIR INTAKE AND EXHAUST SYSTEMS	19
Intake	19
Engine exhaust	19
2.11 MODIFYING THE ENGINE COOLING SYSTEM	20
2.12 MODIFICATIONS TO THE HEATING/CONDITIONING PLANT	20
Installing an additional heating system	20
Installing an air conditioning system	23
2.13 BODYWORK INTERVENTIONS	23
General information	23
Operations	24
Protection of occupants	26
2.14 CHANGING TYRE SIZE	27
Prescriptions	27
2.15 WORK ON THE BRAKING SYSTEM	28
General information	28
Brake pipes	28
ESP (Electronic Stability Program)	30
ESP SYSTEM Derating	32
2.16 ELECTRICAL SYSTEM: CURRENT INTERVENTIONS AND DRAWS	33
2.17 PART RELOCATION AND ANCHORAGE OF ADDITIONAL UNITS AND EQUIPMENT	33
2.18 TRANSPORT OF HAZARDOUS MATERIALS (ADR)	34
2.19 INSTALLING A RETARDER	34
2.20 REAR UNDER-RUN PROTECTION (RUP)	34
2.21 REAR MUD GUARDS AND WHEEL ARCHES	34
2.22 RAIN FLAP	35
2.23 SIDE PROTECTIONS	35

CHASSIS INTERVENTIONS

2.1 GENERAL CHASSIS MODIFICATION STANDARDS

Keep in mind that:

- **weldings on the supporting structures of the chassis are absolutely forbidden** (except as prescribed in Paragraph "Weldings" and in Chapters 2.4 , and 2.5);
- **no holes may be drilled on the wings of the side members** (except for that stated in Chapter 3.3 - Paragraph "Choosing the type of connection" (➡ Page 11));
- for cases where modifications to nailed unions are allowed, the nails may be replaced with flanged head screws or with hex head screws classed 8.8 with the next higher class diameter and nuts fitted with an anti-unscrewing system. Screws larger than M14 may not be used (maximum hole diameter of 15 mm), unless otherwise specified;
- for cases where unions that require screws are restored, the suitability of these screws must be checked before being re-used, and they must be tightened to the appropriate torque;



- ▶ **As regards remounting safety components, it is prohibited to re-use the same screws and tightening must be done at the specified torque (contact the Service Network for the value).**

- for cases involving remounting of safety components where nails are replaced by screws, the union must be checked again after about 500 - 1000 km of travel.

Preventive measures



- ▶ **When welding, drilling, milling and cutting near brake hoses and electrical wires, be sure to adopt appropriate precautions for their protection; disconnect these parts if necessary (respect the prescriptions in Chapters 2.15 and 5.7).**

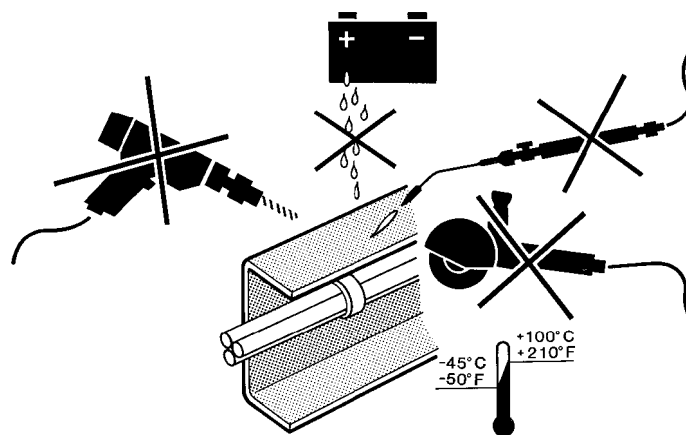

91444

Figure 1

Precautions for alternators and electric/electronic components

In order to avoid damage to the rectifier diode, the battery must never be disconnected (or the isolator switch opened) while the engine is running.

In cases where the vehicle must be started by towing (strongly discouraged), make sure that the battery is charged and connected so as to ensure minimum supply voltage to the engine ECU.

Recharge the battery only after disconnecting it from the vehicle circuit. If the engine must be started-up with external charging equipment, be sure to avoid using the "Start" function (should these devices feature this function) in order to avoid peak currents that may damage electric and electronic components.

Start-up must be performed only via an external battery trolley, making sure that polarity is respected.

Earth connection

The original earth connections of the vehicle should never be altered; in cases where these connections must be moved or new connections added, use the holes present on the chassis to the extent possible, taking care to:

- mechanically remove - either by filing and/or with a suitable chemical based solution - the paint on both the chassis and terminal side, thus creating a contact surface free of indentations and edges;
- paint the area between the terminal and metal surface with a suitable high conductivity paint.
- connect to earth within 5 minutes after application of the paint.

For ground connections at the signal level (e.g. sensors or devices with low absorption), absolutely never use standardised IVECO M1 points (ground connection of the batteries), M2 or M8 (grounding the starter motor, depending on the position of the guide) and connect the signal cable ground on points separate from the power cables and wires that serve as radio frequency screens.

Avoid earth connections between devices in a concatenated fashion for electronic equipment; install individual earth connections of optimal length (favour the shortest routes).

Braking and electrical systems

For additional details on the braking and electrical systems see Chapters 2.15 (► Page 28) and 5.4.

Characteristics of the material used in chassis modifications

For chassis modifications on the vehicle (all models and wheelbases) and for applications of reinforcements on the side members, the material used must correspond to the original chassis material in terms of quality and thickness (see Tables 2.1 and 2.2).

If it is not possible to procure materials of the thickness indicated, materials having immediately higher standard thickness may be employed.

Table 2.1 - Material to be used in chassis modifications

Name of steel		Breaking strength [N/mm ²]	Yield stress [N/mm ²]	Elongation
IVECO	Fe E490	610	490	23%
Europe	S355J0W			
Germany	QStE500TM			

Table 2.2 - Section dimension and chassis thickness

Class	Type	Wheelbase [mm]	Rear overhang chassis [mm]	A x B x t Side member section wheelbase area [mm]	A x B x t Side member section rear overhang area [mm]
35S - 55S	truck	3050	801	134 x 60 x 5	134 x 60 x 5
		3400	962		

Stresses on the chassis

The following stress value in static conditions cannot be exceeded for any reason whatsoever:

Note Permitted static stress on the chassis: $\sigma_{adm} = 100 \text{ N/mm}^2$

In any case, respect any more restrictive limits placed by national standards.

Welding causes material property deterioration; therefore, when checking stresses in thermally altered zones, a resistance reduction of 15% must be accounted for.

2.2 DRILLS ON THE CHASSIS

Installation of auxiliary equipment onto the chassis must be done using the factory drilled holes whenever possible.



► **It is strictly forbidden to drill holes into the side member flaps, with exception to what is indicated in Chapter 3.3 - Paragraph "Choosing the type of connection".**

When new holes must be made for specific applications (installation of shelves, corner shelves, etc.), these must be drilled into the upright rib of the side member and must be thoroughly de-burred and bored.

Hole position and size

The new holes must not be drilled into the areas subjected to greater stresses (such as spring supports) or where the side member section varies.

Hole diameter must be suited to sheet metal thickness but cannot exceed 13 mm (unless otherwise stated). The distance of the axis of the holes from the edge of the side member must not be less than 30 mm; in the same way, the axes of holes must not be less than 30 mm from each other or from other existing holes.

The holes must be offset as in Figure 2.

The original hole layout must be maintained when moving spring supports or crossbars.

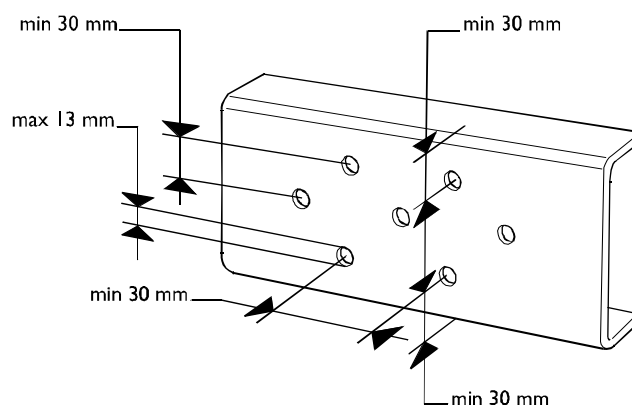

102420

Figure 2

Screws and nuts

We generally recommend the use of the same type and class of screws and nuts as those employed for similar anchorages on the original vehicle (see Table 2.3).

Table 2.3 - Screws resistance classes

Resistance class	Use	Breaking strength [N/mm ²]	Yield stress [N/mm ²]
8.8	Intermediate resistance screws (crossbars, shear resistant plates, brackets)	800	640
10.9	High resistance screws (springs supports, stabiliser bars and shock absorbers)	1000	900

Screws classed 8.8 and 10.9 must be well cleaned and, for applications using a screw with a diameter of ≤ 6 mm; we recommend protection FeZnNi 7 IV.

Screw treatment allowed is Geomet or zinc coating. Geomet treated screws are discouraged when using them in welding operations.

Use flange headed screws and nuts if there is sufficient space.

Use nuts with an anti-unscrewing system and keep in mind that the tightening torque must be applied to the nut.

Sealing holes by welding

If new holes are located near old holes (see Figure 2), these last can be welded shut.

Good results are obtained by:

- chamfering the outer edge of the hole;
- applying a copper plate on the inner edge of the side member to hold the welding material;
- welding the side member on both sides with elimination of all residual material.

Holes of 20 mm diameter can be sealed off by using chamfered washers welded on both sides.

2.3 RUST AND PAINT PROTECTION

Note All components mounted on the chassis must be painted in compliance with IVECO Standard 18-1600 Colour IC444 RAL 7021 - 70/80 gloss.

Original vehicle parts

The following tables show, respectively, the classes of coating and protection required for the original vehicle components, the protections required for the parts not painted or in aluminium and treatments required for the painted parts.

Table 2.4 - Class of protection - IVECO Standard 18 - 1600 (Prospectus I)

Class	Part requirements	Examples of parts involved
A	Parts in direct contact with atmospheric agents	Bodywork - Rear-view mirrors - Windscreen wipers - Metallic structured sun visors - Metallic bumpers - Cab hook lock - Door stop device - Bodywork fastening elements (screws, bolts, nuts, washers), etc.
B B2	Parts in direct contact with atmospheric agents that mainly have structural characteristics, in clear sight	Frame and relative parts, including its fasteners Parts below the radiator grille (class B) External cab ramps
B1		Only for rear axles and front axles
C	Parts in direct contact with atmospheric agents, not in clear view	Engine and relative parts
D	Parts not in direct contact with atmospheric agents	Pedals - Seat coverings - Fastening elements - etc., mounted inside the cab

Table 2.5 - Unpainted aluminium parts - IVECO Standard 18 - 1600 (Table IV)

Type of protection	IVECO standard	Classes					
		A	B - B1 - B2	C	D		
Stainless steel ⁽¹⁾	18-0506	-	-	-	-		
Geomet ⁽²⁾	18-1101	yes	-	-	-		
						GEO 321-8	
						GEO 500-8	
						GEO 321-8 PM	
						GEO 321-8 PML	
						GEO 321-8 PL	
	GEO 500-8 PL						
	-	18-1102	-	yes	-	-	
							GEO 321-5
							GEO 500-5
							GEO 321-5 PM
GEO 321-5 PML							
GEO 321-5 PL							
GEO 500-5 PL							
Zinc coating ⁽³⁾	18-1102	-	-	yes	yes		
						Fe/Zn 12 II	
						Fe/Zn 7 IV	
						Fe/Zn 12 IV	
						Fe/Zn 7 IV LUB	
						Fe/Zn 7 IV S	
Fe/Zn 12 IV S							
Alloy Zn-Ni	FIAT 9.57409	-	yes	yes	yes		

Type of protection		IVECO standard	Classes			
			A	B - B1 - B2	C	D
Alloy Zn-Ni	Fe/Zn Ni 7 IV	FIAT 9.57409	–	yes	yes	yes
Aluminium	Anode oxidation	I8-I148	yes	yes	yes	yes
	Painting	See Table III	yes			

(1) Coupling with other materials must not cause the "battery effect".

(2) Coatings free from chromium salts.

(3) Coatings free of hexavalent chromium.

Table 2.6 - Painted parts - IVECO Standard I8 - I600 (Prospectus III)

Cycle phase description		Classes					
		A	B (8)	B1 (5)	B2	C	D
MECHANICAL SURFACE CLEANING (1)	Sand/shot blasting	–					
	Brushing	yes (*)	yes (*)	–	yes (*)	yes (*)	yes (*)
	Sandpapering						
PRE-TREATMENT	Iron phosphating (only for non-precoated ferrous materials)	–	yes (*)	–	yes (*)	yes (*)	yes (*)
	Zinc phosphating (**)	yes					
CATAPHORETIC PAINTING	High thickness (30-40 µm)	yes (2)	yes (*) (6)	–	yes (*) (6)	yes (*) (6) (9)	yes (*) (6)
	Medium thickness (20-30 µm)	yes (3)					
	Acrylic finishing (>35 µm)	–					
RUST PREVENTER	Bi-component (30-40 µm)	–	yes	–	yes	yes (*) (9)	yes (*)
	Single-component (30-40 µm)		–	yes	–		
ANTIROCK PRIMER	Single (130 °C) or bicomponent (30-40 µm)	yes (3)	–	–	–	–	–
VARNISH	Single (130 °C) or bicomponent (30-40 µm)	yes	yes (*)	–	–	yes (*)	yes (*) (7)
	Powders (40-110 µm)	yes (4)					
	Low temperature single-component (30-40 µm)	–					

(1) This operation must be performed when dealing with cutting burr, oxidation, weld slag, or laser-cut surfaces.

(2) Two-layer bodywork cycle.

(3) Three-layer bodywork cycle.

(4) In alternative to single and bi-component paint only for particular bodywork (windscreen wipers, rear-view mirrors, etc.).

(5) Only rear/front axles.

(6) Excluding parts that cannot be immersed in pre-treatment baths or undergo painting because of compromised functionality (e.g.: mechanical parts).

(7) Only if the colour is defined in a drawing according to I.C.

(8) For fuel tanks in ferrous or pre-coated sheets.

(9) Only parts to mount on the engine.

(*) Alternative products and cycles for the same phase under the condition of comparability with the part to treat.

(**) Specific phosphates must be used for zinc coated or aluminium sheets.

Added or modified parts

All vehicle parts (body, chassis, equipment, etc.) that are add-ons or subjected to modifications must be protected against oxidation and corrosion.

Areas free of protection on ferrous materials are not accepted.

Tables 2.7 and 2.8 indicate the minimal treatment that modified or added components must receive when it is not possible to have protection that is similar to that of original components. Different treatment is allowed if it ensures similar oxidation and corrosion protection.

Do not use powder varnish directly after degreasing has been performed.

Lightweight alloy, copper and brass parts must be protected.

Table 2.7 - Painted modified parts or add-ons

Cycle phase description	Class
	A - B -D ⁽¹⁾
Mechanical surface cleaning (including elimination of burrs/oxidation and cleaning of cut parts)	Brushing/sandpapering/sand blasting
Pre-treatment	Degreasing
Rust preventer	Bi-component (30-40 µm) ⁽²⁾
Varnish	Bi-component (30-40 µm) ⁽³⁾

⁽¹⁾ Modifications on rear axles, from axles and engine (classes B1 and C) not allowed

⁽²⁾ Preferably epoxy

⁽³⁾ Preferably polyurethane

Table 2.8 - Unpainted or aluminium modified parts or add-ons

Type of protection	Class	
	A - B ⁽¹⁾	D
Stainless steel	yes	–
Geomet		–
Zinc coating ⁽¹⁾	–	yes

⁽¹⁾ Free from hexavalent chromium

Precautions

a) On the vehicle

Appropriate precautions must be taken to protect parts on which paint could be harmful to the conservation and operation thereof:

- hoses for pneumatic and hydraulic systems in rubber or plastic, **with particular reference to the braking system**;
- gaskets, rubber or plastic parts;
- drive shaft and PTO flanges;
- radiators;
- suspension, hydraulic/pneumatic cylinder stems;
- air vent valve (mechanical assembly, air tank, thermostarter preheat tanks, etc.)
- sediment bowl and fuel filter assembly;
- plates, codes.

If painting is required after wheels are removed, it is necessary to:

- Protect the wheel rim mounting surfaces on the hubs and the contact areas of the locking lugs/wheel studs;
- ensure adequate protection of brake discs.

The electronic components and modules must be removed.

b) On engines and their electric and electronic components

Appropriate precautions must be taken to protect:

- engine wiring and ground contacts;
- the sensor/actuator side connectors and wiring side;
- the sensors/actuators on the flywheel and on the flywheel rpm sensor mounting bracket;
- pipes (plastic and metal) of the fuel circuit;
- complete basic diesel filter;
- the ECU and its base;
- the entire internal part of the sound-proof cover (injectors, rails, pipes);
- the common rail pump and its control valve;
- the vehicle electric pump;
- tank containers;
- the front V-belts and relative pulleys;
- the power steering pump and relative pipes.

Note *When the painting operation has been completed, and prior to oven drying (max. temperature. 80 °C), all parts which may be damaged by exposure to heat, must be removed or protected.*

2.4 WHEELBASE MODIFICATION

Variation of the wheelbase is only permitted upon specific approval of IVECO.

In any case, the following must always be taken into account:

- lengthening the wheelbase has a negative effect on the steering (turning circle, effort applied on the steering wheel and vehicle reaction times as contained in the ECE Regulation or EC Directive in force);
- shortening the wheelbase will have a negative effect on braking.

2.5 REAR OVERHANG MODIFICATION

Any rear chassis lengthening must be explicitly authorized by IVECO.

2.6 INSTALLING THE TOW HOOK

General information

Conversion from non-trailer version to type approved trailer version is allowed without requiring specific authorisation from IVECO.

Note *A vehicle not originally intended for towing may be adapted to this purpose by adding the specific "trailer section", i.e. inserting the set of components listed in the type-approval documentation for the trailer version (chassis cross member, electrical coupling union, tow coupling, chronotachograph, etc...).*

However, bear in mind that fitting the chronotachograph, when necessary in relation to current legislation, must be only carried out by the IVECO Assistance Network.

Precautions for Installation

The towing hook must be suited for the loads allowed and must be of a type approved by national standards.



▶ **Given their importance related to safety, the drawbar couplings must not undergo modifications.**

In addition to the requirements of the hook manufacturer, it is necessary to respect the limitations imposed by the Regulations on:

- clearances required for the coupling of the brakes and electrical system;
- distance between the hook pin axis and the rear edge of the superstructure (see Figure 3).

In the European Community (UN-ECE Regulation No. 55), this will normally be about 420 mm, but values are allowed up to 550 mm if an appropriate mechanism is adopted for safe operation of the hand lever. For even higher values it is advisable to consult the aforementioned Regulation.

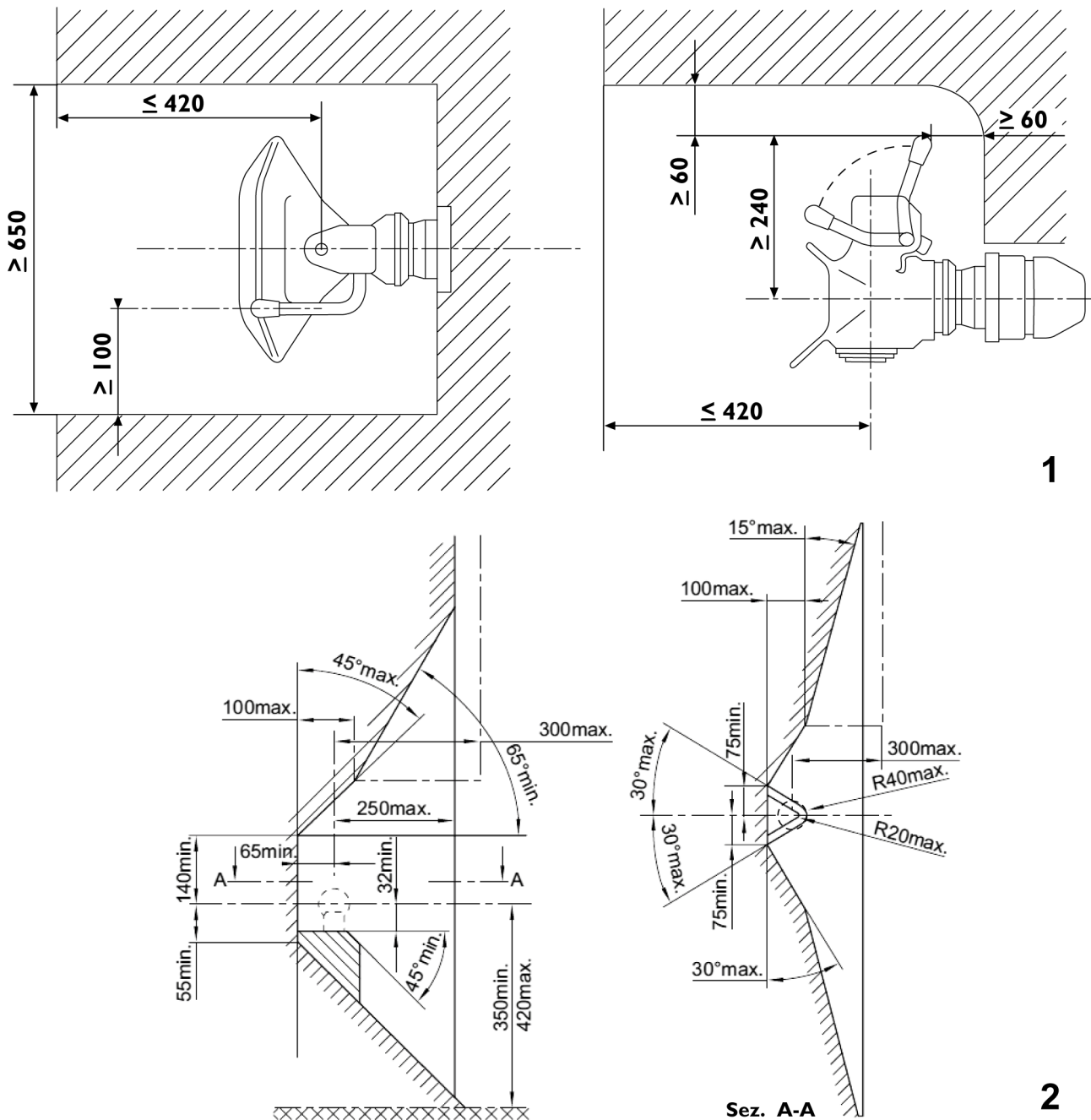

196787

Figure 3

1. Free field for towing hooks

2. Free field for coupling hooks according to standard DIN 74058 ESC-I52

In cases where the connection flange of the drawbar coupling does not have holes suitable to those on the existing rear crossbar of the vehicle, the latter may be authorised for modification upon application of adequate reinforcements.

The Body builder has the duty of realising and installing the superstructure so as to allow coupling connection and checks without impairment or hazard of sort.

The trailer drawbar must be guaranteed freedom of movement.

Drawbar couplings for centre axle trailers

Centre axle trailers are defined as those that have the drawbar rigidly connected to the frame and the axle (or more close axles) placed at half the length of the same chassis.

Compared to the articulated drawbars, the rigid drawbar acts on the drawbar coupling with the increase of the static vertical loads and, in the braking phase or in the oscillations caused by the road surface, the increase of the dynamic vertical loads. By means of the hook, these loads lead to increases in the torsion of the rear crossbar of the vehicle, as well as push-ups on the overhang.

The use of centre axle trailers therefore requires the use of suitable towing hooks.

The values of the towed weights and vertical loads allowed are listed on the technical documents of the drawbar coupling manufacturer and on the part manufacture plate (see DIN 74051 and 74052).

For mechanical coupling devices for trailers with a central axle, refer to the following formulas:

- $D_c = g(T \cdot C) / (T + C)$
- $V = a \cdot C(X^2 / L^2)$

D_c = representative value of drawbar class [kN]. This is defined as the determination of the theoretical reference value for horizontal load between tractor

g = acceleration of gravity [m/s^2]

T = maximum weight of the towing vehicle [kg]

R = maximum weight of the trailer [kg]

S = value of vertical static load that, in static conditions, is transmitted to the coupling point. S must be $\leq 0.1 \times R$ and, in any case, less than 1000 kg

C = sum of maximum axial loads of the centre axle trailer at full load. It is equal to the maximum mass of the trailer decreased by the vertical static load ($C = R - S$)

V = value of the theoretical dynamic vertical load [kN]

a = vertical acceleration in the area of the drawbar coupling/hook. in function of the rear tractor suspension, use the following values:

- $a = 1.8 m/s^2$ of air suspensions
- $a = 2.4 m/s^2$ for other types of suspensions

X = length of the load bed [m], (see Figure 5)

L = theoretical drawbar length, distance between the centre of the drawbar eye and the centre line of the trailer axles [m], (see Figure 5)

$X^2 / L^2 \geq 1$ if the result is less than the unit, use the value 1

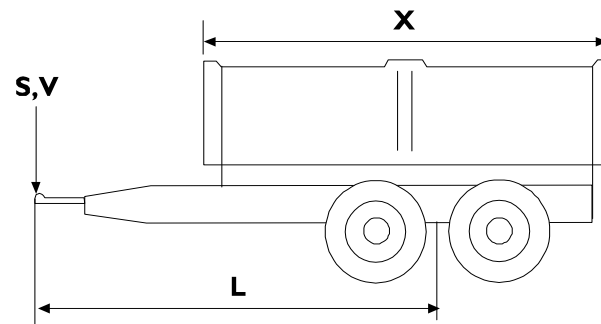

193864

Figure 4

X. Length of the trailer load bed

L. Theoretical drawbar length

As original equipment, the DAILY 4x4 vehicles may be fitted with a "mixed" type tow hook, i.e. ball type with safety device. This tow hook may only be fitted on the rear closing cross member of the chassis.

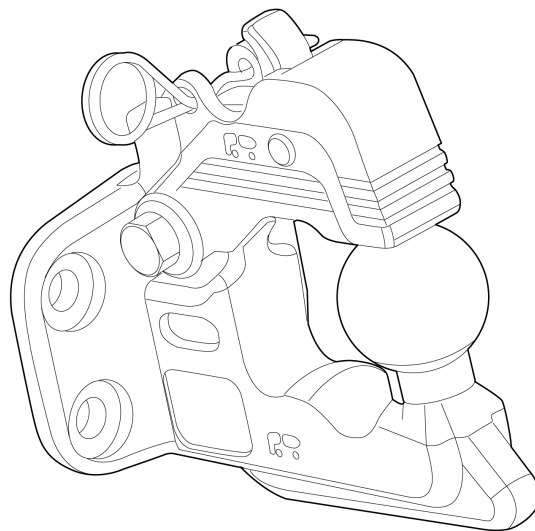

120361

Figure 5

The following chart contains the data of tow hook versions which are available in production.

Table 2.9 - Type-approved hooks

type	Class	D [kN]	Dc [kN]	S [kN]	N° ECE type approval
70C 4x4	A50-X	31	–	3.75	0112261
70C 4x4	S	31	–	3.75	0112262

If it is not directly supplied by IVECO, then the tow hook must in any case:

- have characteristics that are wholly equivalent to those shown in Table 2.9;
- be approved in observance of the current national and international legislation (eg. EC Directives);
- be fitted in accordance with the manufacturer's instructions.

Note *Any other solutions must be explicitly authorised by IVECO.*

Observations of payload

The static load on the tow hook must not exceed the load allowed on the rear axle of the vehicle. Furthermore, the minimum weight on the front axle must be respected as indicated in Chapter 1.15 .

Increase of tow weight

As regards tow vehicles, IVECO may evaluate - in certain cases and for particular applications - the possibility to authorise greater tow weights than those normally allowed.

These authorisations include the towing conditions and, when necessary, provide the instructions relevant to any vehicle modifications or work required: standard crossbar reinforcements, or installation of a reinforced crossbar when available, or adjustments to the braking system.

The drawbar coupling must be suited for the new use, and its connection flange must coincide with that of the crossbar.

Fix the crossbar to the chassis by using flanged head screws and nuts or hex head screws of 8.8 min. class.

Use anti-unscrewing systems.

Plates

Some countries require a plate to be applied on the towing device, which must list maximum tow load and maximum vertical load allowed.

If not already mounted, the Outfitter shall see to its manufacture and installation.

2.7 ASSEMBLING AN ADDITIONAL AXLE

Application not provided.

2.8 GEARBOX MODIFICATION

Any modifications to the transmission must be authorized by IVECO.

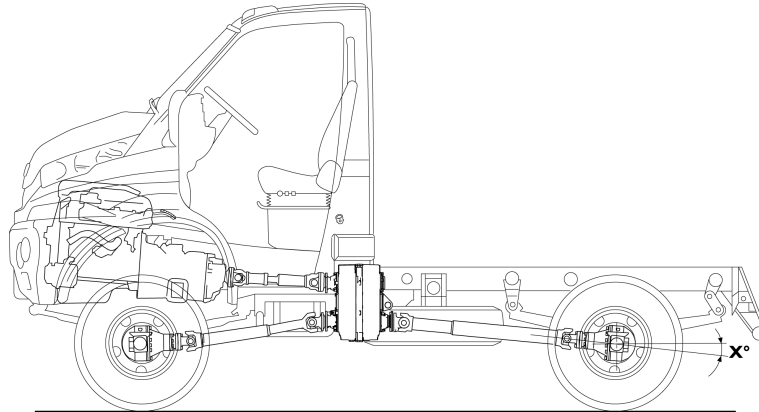

227321

Figure 6

The maximum inclination X° of the rear axle casing must be less than 10° in relation to the horizontal.

Note It is strictly forbidden to move the transfer box.

We recommend using original IVECO gearboxes; if this is not possible, the use of raw steel pipes with a yield load of at least 420 N/mm^2 (42 kg/mm^2) may be used.

The universal joints may not be modified.

For each modification of the transmission, or of any of its parts, careful dynamic balancing must be performed on each modified section.



- ▶ **Given that the transmission is an important part of the vehicle in terms on safety, we strongly recommend that all modifications made to it stand up to maximum safety standards. Therefore, all modifications should be made only by highly specialised Companies that are qualified by the transmission Manufacturer.**

2.9 WORK ON SUSPENSIONS



- ▶ **Modifications to the suspensions and springs (e.g. addition leafs, variations in camber, etc...) affect the driving safety of the vehicle and inasmuch may only be implemented after obtaining approval from IVECO.**

In general, work on parabolic suspensions is not allowed. On vehicles with this type of suspension spring, exception is made for set-ups or special uses for which, in order to increase suspension rigidity, the application of rubber elastic elements may be authorised. In exceptional cases and for specific uses, the possibility may be evaluated of allowing the addition of extra leaf springs on the parabolic springs; this must be carried out by a specialised spring manufacturer after approval by IVECO.

It is not allowed to use a parabolic spring on one end of the axle and a semi-elliptic string on the other end.



- ▶ **On vehicles equipped with an ESP system, modifications of the suspensions are not permitted. See Chapter 2.15 - Paragraph "Derating of the ESP System".**

Note Adaptation of the suspension assumes a corresponding adaptation of the ESP system controlling stability (see Paragraph "Derating of the ESP system" (➡ Page 32)).

2.10 MODIFYING THE ENGINE AIR INTAKE AND EXHAUST SYSTEMS

Note *The characteristics of the engine air intake and exhaust systems must not be modified. Modifications, if authorised by IVECO, must not vary the original intake vacuum and exhaust counter-pressure values.*

Table 2.10 - Maximum allowed back pressure at intake and exhaust under normal operating conditions and at full load

engine	Engine code	Exhaust back pressure [kPa]	Min - max intake back pressure [kPa]
.17 Euro VI	FICFL411F*A	40	1 - 9
.15 Euro III	FICE3481J*LF	15	1 - 8

Intake

The air intake must be mounted as to avoid intake of hot air from the engine compartment, or dust and water.

The intake compartment must be sealed airtight and fitted with rubber gaskets that prevent hot air recirculation. The gaskets must be of high quality as to support a steady temperature of 100 °C, with short durations of 120 °C, without undergoing visible deformations or deteriorations. The compartment must keep airflow sections efficient for the entire circuit.

The holes that must be made in the box part of the van must have an area of about twice that of the cross-section of the pipe upstream of the filter; these openings (e.g. grille holes) must have minimal dimensions to prevent possible clogging.

The following are not allowed:

- alterations or replacement of the original air filter with one of lower capacity;
- modifications to the silencer body;
- intervene on equipment (injection pump, regulator, injectors, etc.) that may compromise good engine performance and affect exhaust gas emissions.
- change the Humidity sensor → Blow-by sequence in the segment between the air filter and turbine.

Lastly, it is necessary to check if new system approval is required in relation to specific national standards (sound level, smokiness).

Engine exhaust

If it is necessary to change the pipe layout despite the availability of various optional solutions in the catalogue, it is advisable to envisage:

- the simplest possible route (curvatures with radii of no less than 2.5 times the outer diameter, passage sections no smaller than those of the original solution, absence of throttling);
- suitable distances (min. 150 mm) from electrical systems and plastic pipes (shorter distances progressively require plate guards, thermal insulators or the replacement of plastic pipes with steel ones).

Authorisation must always be obtained from IVECO.

2.11 MODIFYING THE ENGINE COOLING SYSTEM

The good operating conditions of the original system must not be altered, especially for what concerns the radiator, free surface of the radiator and pipes (dimension and layout).

In any case, if modifications are required (e.g: cab modifications) that entail interventions on the engine cooling system, keep in mind that:

- The air passageway area for radiator cooling must not be less than that on vehicles with series standard cabs;
- maximum air expulsion from the engine compartment must be guaranteed, making sure that there are no hot air pockets of recirculation by adopting guards or deflectors;
- fan performance must not be modified;
- any modifications of the water piping must not compromise complete filling of the circuit (done with a steady flow and without any backflow from the intake until the circuit is filled) and regular water flow; in addition, these modifications must not alter maximum water stabilisation temperature, even in the most demanding conditions of use;
- pipe layout must be done so as to avoid the formation of air pockets (e.g. eliminating siphoning bends or installing required vents) that may make water circulation difficult;
- check that water pump activation at engine start-up and successive operation during idling is immediate (accelerate a few times), even when circuit is not pressurised. During checks make sure that the water pump supply pressure, with engine at top speed and no load, is less than 1 bar.

To check the operation of the cooling circuit we must account for the water supply, bleed and circulation proceeding as follows:

- fill the circuit while the engine is off with a flow rate of 8 - 10 l/min, until water seeps from the overflow vent;
- start the engine and run idle for 5 minutes, successively check to see that the water level in the supply tank has not dropped below minimum level;
- gradually rev the engine, checking that average pressure in the water pump outlet pipes steadily increases without and discontinuities;
- keep accelerating the engine until the thermostat opens, causing air bubbles to pass through transparent pipes installed between:
 - engine output and radiator;
 - water supply tank and water pump;
 - engine bleed and water supply tank;
- check, after the thermostat has been open for 15 minutes, that there are no more bubbles in the circuit;
- check that, with thermostat open and engine running idle, that average pressure in the water pump inlet pipe is greater than 500 mm water column (0.05 bar).

2.12 MODIFICATIONS TO THE HEATING/CONDITIONING PLANT

Installing an additional heating system

We recommend using IVECO type heating systems whenever it is necessary to install an additional heating system.

On vehicles where IVECO does not employ these heaters, installation must be done in compliance with the instructions issued by the equipment Manufacturer (installation of heaters, pipes, electric system, etc.) and in relation to the following indications.

The additional heating system must respect all national standards on the subject (e.g. tests, specific installations for the transport of hazardous materials, etc.). It must avoid the use of vehicle equipment that requires certified approval whenever such equipment may cause a negative impact on performance.

In addition, be sure to:

- care for the proper operation of all other vehicle systems (e.g.: engine cooling system);
- check that the battery capacity and alternator power are sufficient for increased current draw (see Chapter 5.4) and install a protection fuse on the new circuit;

- to draw off the fuel, connect the fuel supply system to an auxiliary tank. Direct connection to the vehicle tank is allowed under the condition that it occurs independently from the engine fuel supply, and the new circuit must be perfectly airtight;
- route piping and wiring layout (and installation of brackets and flexible fittings) in relation to the spaces available and the influence of heat on the chassis parts. Avoid any exposed parts that may be dangerous, and adopt suitable guards when necessary.

The system must allow easy access and prompt maintenance.

The Body builder must provide all necessary maintenance instructions.

a) Water heaters

When the original vehicle heating and engine cooling circuits are involved (see Chapter 2.11 (► Page 20)), the following must be done to ensure good system operation and safety of the original system:

- carefully define the connection points between the additional and original systems, in agreement with IVECO, if necessary. The added pipes must be made of brass or other alloy resistant to the corrosive action of coolant, the coupling sleeves must respect the requirements put forth by the standard IVECO I8-0400;
- plan for a rational layout of pipes, avoiding bottlenecks and siphoning bends;
- install venting valves (bleed points) to allow proper system filling;
- allow complete circuit discharge, also by installing any additional plugs;
- adopt, when necessary, suitable protections to limit heat loss.

b) Air heaters

As regards these heaters and for direct cab installation, be particularly cautious with the exhausts (to avoid combustion gasses from being trapped in the vehicle) and correct distribution of hot air (in order to avoid direct flow).

Figure 7 shows a layout for a supplementary heating system with an additional heater.

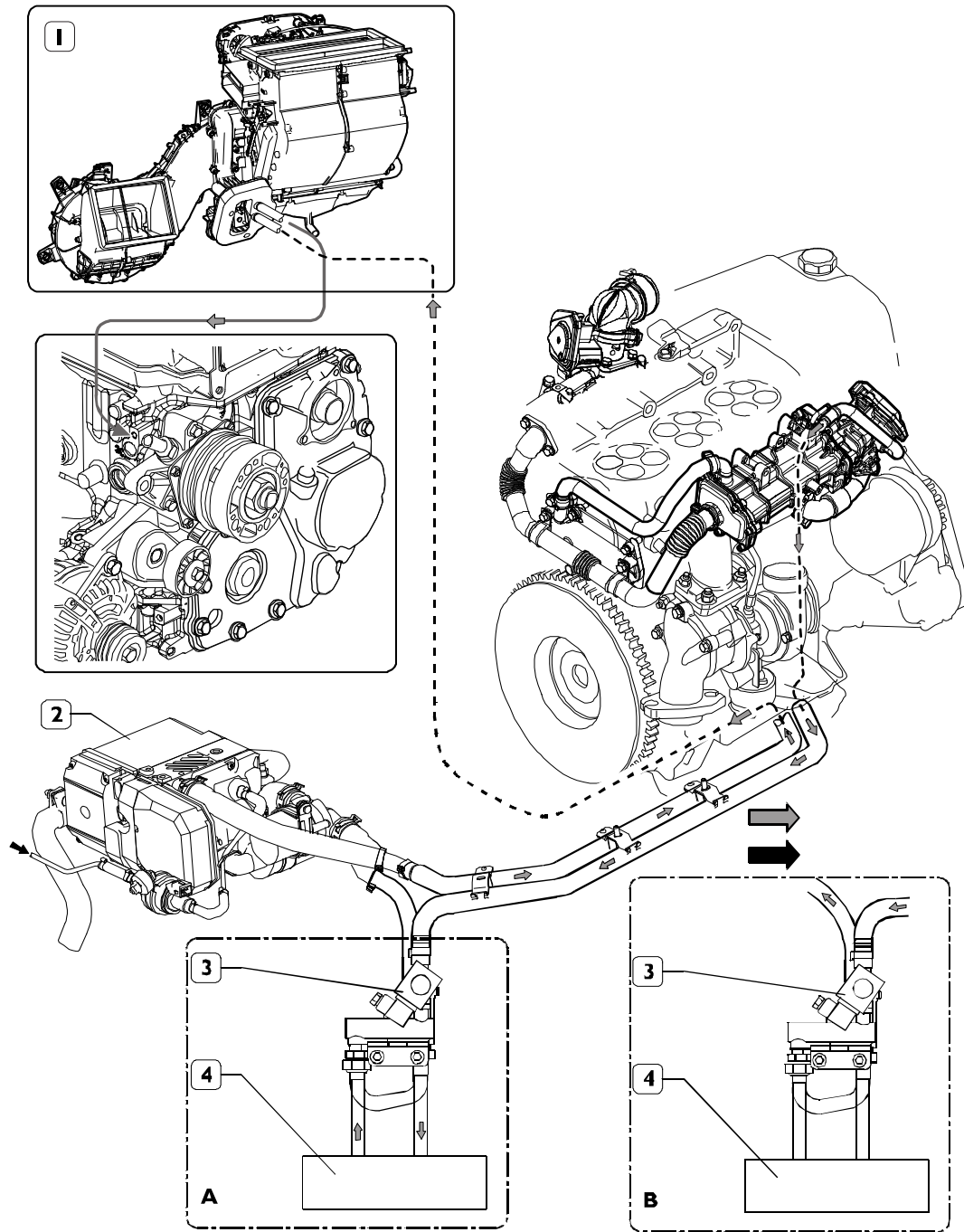

204649

Figure 7

1. Main heater
2. Optional supplementary heater
3. Solenoid valve
4. Additional heater installed by body builder

- A. Solenoid valve (3) open
- B. Solenoid valve (3) closed

N.B. Heaters (2) and (4) may even be present on their own.

Installing an air conditioning system

We recommend using original IVECO units for the installation of an air conditioning system.

When this is not possible, aside from complying with the specific requirements provided by the manufacturer of the equipment, it is necessary to:

- maintain good performance of the vehicle parts that may be involved in the intervention;
- check that the battery capacity and alternator power are sufficient for increased current draw (see Chapter 5.4 - Paragraph "Additional equipment") and install a protection fuse on the new circuit;
- plan the compressor installation modes with IVECO, if installed on the engine;
- route piping and wiring layout (and installation of brackets and flexible fittings) in relation to the spaces available and the influence of heat on the chassis parts;
- avoid layouts and installations where exposure may be dangerous when the vehicle is moving; fit suitable guards when necessary;
- the system must allow easy access and ensure prompt maintenance.

The Bodybuilder must provide all necessary maintenance instructions upon vehicle delivery.

In addition, in function of the type of system:

a) cab installed system:

- condenser installation must not cause negative effects on the engine cooling characteristics (reduction of exposed radiator-engine area);
- the condenser must not be installed together with the engine radiator but in a specific and suitably ventilated bay, unless a condenser is used that is equivalent (in shape and performance) to the standard model envisaged by IVECO;
- installation of the evaporator unit and of the bellow inside the cab (in cases where not provided directly from IVECO) must be planned as not to negatively impact control functions and access to equipment;

b) cab roof-installed systems :

- it is necessary to verify that the mass of the equipment does not exceed the weight allowed by the cab; in addition, the Bodybuilder must define the structural reinforcements to apply to the cab roof in relation to the unit's weight and type of intervention performed;
- contact IVECO or specific applications that involve an unoriginal compressor (e.g. fridge).

Note *Note that in relation to Directive 2006/40/EC on the emissions of air conditioning systems for motor vehicles, the use of fluorinated GHG with overall heating potential over 150 in comparison to CO₂ is prohibited.*

2.13 BODYWORK INTERVENTIONS

General information

All interventions on the steering cab must be authorised by IVECO in advance.

The modifications must not hinder operation of the control devices located in the area of the modification (e.g. pedals, switches, pipes, etc.) nor alter the strength of load-bearing elements (frames, reinforcement profiles, etc.). Care must be taken when dealing with operations that regard the engine cooling and air intake pipelines.

In relation to variation of cab weight, it is necessary to consider the position of the load in order to respect division of allowed axle loads I.15 (► Page 11)).

As regards operations that entail the removal of internal sound barriers or protective panels (panelling, cladding) be sure to remove only the minimum amount possible; restore the protections as intended in the original design along with their original functionality.

Cab installation of controls and equipment (PTO engage switch, external operator cylinder control, etc.) is allowed as long as:

- installation is rational, performed in good detail and easy to access by the driver;
- the proper safety, control and signalling devices called for by national law are installed.

Make sure that the pipes and cables are installed correctly; adopt the necessary retainers and be sure to plan for appropriate distances from the engine, heat sources and moving parts.

Each structural modification must bear protection against corrosion (see Chapter 2.3 (► Page 9)).

The use of zinc coated sheet metal is recommended on both ends of newly inserted sheet metal on cut bodywork in order to avoid ferrous corrosion of the welds (I.S. 18-1317 class ZNT/F/10/2S or I.S. 18-1318 class ZNT/10/2S); both surfaces must undergo protective treatment.

Install gaskets with care and apply sealant to areas in need of protection.

Make sure that the seals are water, dust and smoke tight.

The Bodybuilder must check that the chassis, after its structural modifications, complies with the standards in force for what concerns both internal and external structure.

Operations

a) Cab

Any cab modifications performed to create specific configurations must be done with care in order to protect the resistance and maintain cab functionality and protections intact.

In the installation of units on the roof (e.g. air-conditioning systems), make sure that the weight of the equipment does not exceed that permitted by the cab. The applicable limits can be provided on request, depending on the version.

If an opening has to be made, the following is required:

- envisage coupling radii of no less than 50 mm;
- do not modify any ribbing that may be present;
- do not modify the curvature of the roof.

b) Installation of spoiler or box on the roof

Upon request, versions are available developed for IVECO on the basis of their designs and verifications.

If "kits" of other origins are fitted, follow the specific indications supplied by the manufacturer.

In any case, please note that the possible lack of contact between the superstructure and roof may trigger air turbulence resulting in fastidious vibrations or resonances; therefore the application of gaskets or sealing systems that protect the aerodynamics is strongly recommended.

If the national standards require it, these installations must be controlled by relevant type-approval authorities.

c) Roof and cab rear wall

If the rear wall and part of the roof have to be removed (e.g. auto-caravan set-ups), bear in mind the following indications:

- make the cut as shown in Figure 8, making sure to comply with the minimum coupling radii indicated;
- eliminate the rear cross member structure at roof level;
- implement a structure capable of ensuring that uprights cannot be deformed in order to retain the efficiency of the upper couplings of the safety belts;
- this structure should have a compression strength of at least 800 daN;
- implement the connection with the new structure following the general indications provided above.

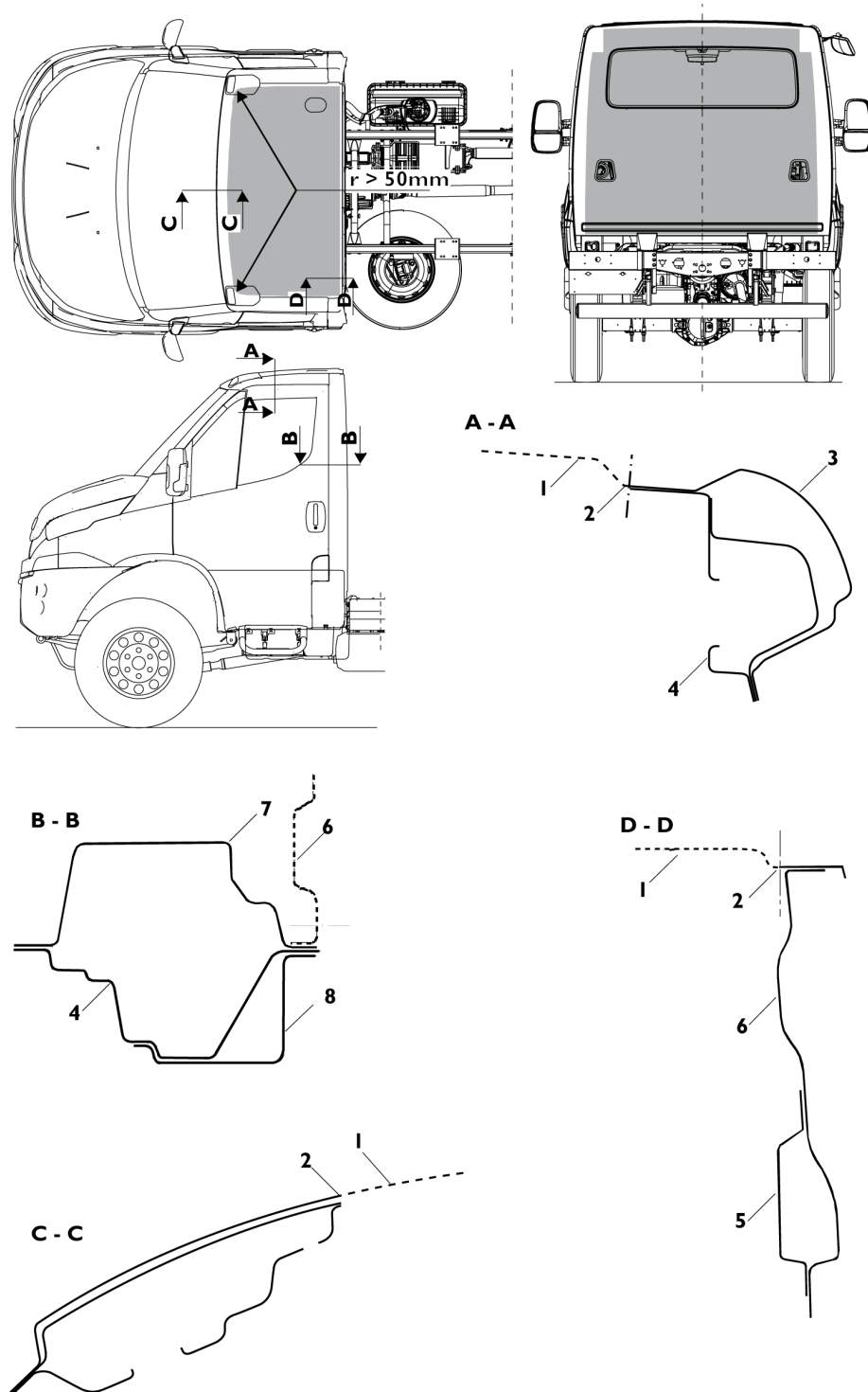

228310

Figure 8

- 1. Roof panel
- 2. Cutting limit area
- 3. Side finishing of roof
- 4. Door support ring

- 5. Internal rear cross member
- 6. Rear wall
- 7. Door area rear finishing
- 8. Side finishing

d) Realization of sleeper cabs

In the realization of sleeper cabs (e.g. 8+1), for special vehicles, municipal applications, fire brigade etc., the suspension must be adapted to the increased weight and to any extra places that are realized.

To perform work of this kind, confirmation must be obtained from IVECO of the suitability of the original suspension devices.

In outline, it may be possible to adopt solutions that are equivalent to those envisaged in routine production for similar versions.

Defining a suitable suspension system must:

- respect the cab structure provided in the standard vehicle;
- avoid that added weight causes serious damage to the original parts of the cab and relative suspension;
- ensure the normal oscillations along the vertical, longitudinal and transverse plane.

To help maintain the integrity of the cab, it is recommended to keep the rear structure as much as possible unchanged. The cut must be made laterally without damaging the door ring.

The bodybuilder must make the necessary connections to the load-bearing structure, comprising the longitudinal profiles and the uprights, connecting the new floor to them; inspection panels must also be provided, if necessary.

It is advisable to pay special attention to the surface preparation of parts to be welded (using a zinc primer) and to adopt the necessary precautions to ensure good preparation of the base for subsequent painting (see Chapter 2.3 (► Page 9)).

When modifying the cab, components such as the air intake and the filter may be involved. The use of original elements already provided for similar fittings, can be a good solution and allow the compliance with legislative regulations.



- **A deep cab may affect the handling and safety of the vehicle (suspension, commands). Inasmuch, it must be carried out with the utmost care and all necessary precautions.**

Protection of occupants

The connections of safety belts, the positioning of reels and pre-tensioners and the anchorage of seats are all an integral part of passive safety.

Any modification of these components may compromise the protection of persons on-board and compliance with legal requirements.

a) Anchorage of safety belts

Work in the body areas where there are seat belt fittings may affect the function/operation of these devices.

It is therefore the responsibility of the Body builder to comply with regulations concerning:

- mounting and tightening torques
- choice of seat belts other than original versions;
- uniform operation between original seat belts and seats that may have a different configuration to the originals.

b) Seats

Moving or fitting additional seats is only permitted on vehicles originally fitted with supplementary anchoring points and already subject to alternative type approval.

Any other solution is implemented under to total responsibility of the body builder as regards installation and final test procedures (destructive).

2.14 CHANGING TYRE SIZE

Note Replacing the tyres with others of measure or load bearing capacity that differs from the specifications recorded at vehicle approval require IVECO certification, as well as a test to determine whether the braking system requires adjustment.

The vehicle must then be presented to the competent Body that will inspect the new tyres and the vehicle documents.

Mounting larger tyres:

- always requires a size check in relation to mechanical components, wheel arches, etc., in the various dynamic, steering and vehicle shaking conditions;
- may entail rim replacement with the consequential need to verify the spare tyre holder modification;
- may affect distance from ground of the rear under-run protection device and, in this case, a check on standard compliance is required; if necessary the support brackets must be replaced with appropriate and approved counterparts (see chapter 2.20 (► Page 34));
- requires the need to check compliance of the limit transversal contour allowed in relation to the various standards.

Prescriptions

Note Replacing tyres with others of different external diameter affects vehicle performance (e.g.: speed, max. vehicle ramp slope, tow load, braking force, etc.); therefore the body-computer (speedometer, tachograph and speed limiter) must be subject to recalibration at an authorised IVECO workshop.



► **Tyres of different size and type of structure cannot be mounted on the same axle.**

The tyre load bearing capacity and the relative reference speed must be suitable to the vehicle's performance.

Mounting tyres with lower load bearing capacity or reference speed entails a reduction of allowed loads; on the other hand, mounting tyres with greater load bearing capacity does not automatically entail an increase of load allowed on the axles.

The dimensions and load bearing capacity of the tyres are established by international and national standards (ETRTO, DIN, CUNA, etc.) and are listed in the manuals of their respective Manufacturers.

Particular performance values may be envisaged by national standards for special uses, fire-protection, winter services, airport tank trucks, buses, etc.



► **If vehicle configuration requires the wheels to be removed, make sure that the contact surfaces between rim and connection flange are clean and free of corrosion when remounting the wheels. In addition, tighten the wheel studs at the tightening torque according to the IVECO standard (see the following Table).**

Table 2.11 - Wheel tightening torques according to IVECO STD 17-9219

CONNECTING ELEMENTS		TIGHTENING			
Name	Thread	CLASS	Torque [Nm]		FEATURES "S" (*)
			Min	Max	
Front and rear wheel mounting (33S-55S)	Stud M18x1.5	II	305	375	"S"

(*) Characteristic "S": safety tightening (see IVECO std. 19-0405).



- ▶ **If using brackets to mount aesthetic studs positioned between the rim / lug or stud, or if using rims thicker than the original, geometric mounting functionality must be ensured through appropriate lengths of stud threading in the locking hole.**

2.15 WORK ON THE BRAKING SYSTEM

General information

The braking system, together with its components, is of fundamental importance in terms of safety.



- ▶ **Any modification to the braking system requires authorisation from IVECO, it being understood that no changes may be made to the following parts: brake cylinders and callipers, adjustment units and valves, parking brake, brake control and auxiliary systems.**

If the national standards provide it, the vehicle must be presented to the competent authority for inspection.

Brake pipes



- ▶ **It is absolutely forbidden to weld the pipes.**

Note *In the case of changes to the cantilever, the brake lines involved should preferably be replaced with new pipes and in one piece. If it is not possible to use one-piece pipes, the couplings to be used must be of the same type as the original ones in the rest of the system.*

In the event of replacements the minimum internal dimensions, material and curvature radii of the pre-existing pipes must be respected.

For procurement please contact IVECO Assistance Service, whereas for assembly the directions in IVECO STD 17-2403 must be complied with.



- ▶ **The total or partial painting of the brake pipes must be absolutely avoided and, for this purpose, appropriate masking of the pipes must be provided.**

Metal pipes

Additions and replacements must envisage:

- for materials, dimensions, couplings: Standard ISO 4038
- radii of curvature (referring to the centre line of the pipe $\varnothing = 4.76$ mm): min 25 mm
- tightening torque:
 - stiff pipes, couplings M10x1 and M12x1: 14÷18 Nm
 - hoses, male couplings M10x1: 17÷20 Nm

Preparation and assembly (IVECO STD 17-2403)

Cut the pipe at right angles (15° maximum error), using a special tool in order to avoid imperfections that affect the sealing.

Permanently mark the section of pipe (dimension L in Figure 9) to be inserted into the coupling to ensure secure sealing.

Mark the pipe to avoid assembly errors in case of subsequent repair operations.

As much as possible, use the same couplings as the original ones, or otherwise belonging to the normal production of specialised manufacturers in the sector.

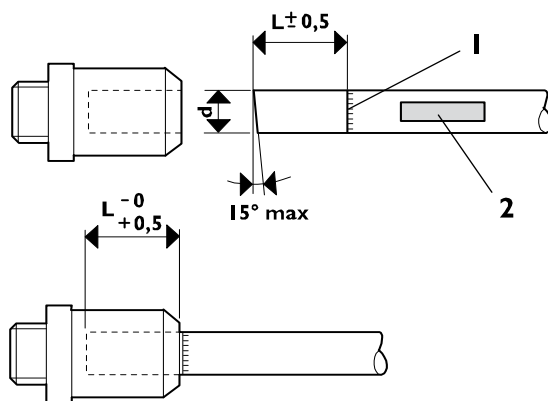

d (mm)	L (mm)
4	19,5
6	19,5
8	20,5

208209

Figure 9

1. Identification of pipe limit

2. Marking

As much as possible, use quick-fit couplings.



► **For each intervention on the piping, verify whether there is the need, depending on the supplier, to use always new couplings or if it is possible to reuse those originally present through the use of appropriate tools (pliers).**

When the space conditions require it (e.g. in proximity of curves), couplings with metal inserts can be used.

Before inserting the pipe into the coupling, screw the coupling into the threaded insert of the same component (e.g. pneumatic valve), using the following values for tightening:

Table 2.12

Thread	Tightening torque [Nm ± 10%]
M 8 x 1 mm	20
M 12 x 1.5 mm	24
M 14 x 1.5 mm	28

Insert the pipe into the coupling for the previously marked stretch of length L, using a force of between 30 and 120 N, depending on the size of the tube.

The replacement of components (valves, etc..) is made possible because the engagement and coupling allow an internal rotation during the operation of unscrewing and screwing.

Vehicle pipe installation

Before use, the new pipes must be thoroughly cleaned inside, for example by blowing air with a compressor.

The pipes must be fixed to the frame with elements which envelop the pipe completely and which may be metal with rubber/plastic protection or be made of plastic material.

Provide appropriate distances between one fastening element and the other: generally, max. 500 mm for plastic pipes and max. 600 mm for metal pipes can be considered.

In order to avoid deformations and tensions at the time of closure of the couplings for the plastic pipes, it is necessary to take care of the line and the accommodation of the fastening elements, rubbing should be avoided with the fixed parts of the vehicle and meet the necessary safety distances from moving parts and heat sources.



- ▶ **After each intervention, both on the system and on the equipment, it is necessary to perform a precise air bleed operation (on vehicles with the ABS/ESP system only using special apparatus present in the IVECO Authorized Workshops).**

Note *The fluid discharged from the hydraulic circuit must not be used again. Top up using only new fluid of the prescribed type, contained in original, sealed containers that should only be opened when using the fluid.*

Bleed air using "E.A.SY." on vehicles with ABS//ESP system

The conventional manual bleed operation may not be sufficient on vehicles equipped with the ABS/ESP system.

Therefore the operation must be carried out which will be guided by "E.A.SY." This makes it possible to perform a full bleed (primary circuit and secondary circuit of the modulator).

Follow the instructions as they are displayed, making sure not to exceed the pump and solenoid activation time to avoid super-heating the components.

If this happens, the system switches off and you must wait for the preset time before resuming the operation.



- ▶ **When replacing the modulator (supplied by IVECO Parts already filled with brake fluid in every part), it is enough to use the manual bleed procedure, taking care however not to empty it and not to cycle the pump and solenoid before filling is completed.**

The ABS/ESP modulator devices are situated on the chassis in the engine compartment and must not be moved.



- ▶ **Perform the necessary checks and controls after every such task at an Authorised Workshop having specific equipment.**

ESP (Electronic Stability Program)

ESP is an electronic function which contributes to the vehicle's active security and therefore the European Legislation, relating to vehicles approved also for off-road use, provides that it is obligatory up to GVW of 3.5 t.

Through the continuous analysis of acceleration signals, yaw, steering angle and wheel revolutions (see Figure 10), an ECU compares the set trajectory with that actually travelled by the vehicle.

if there is the danger of instability, the system activates the modulated braking of one or more wheels and intervenes in engine management by reducing its speed.

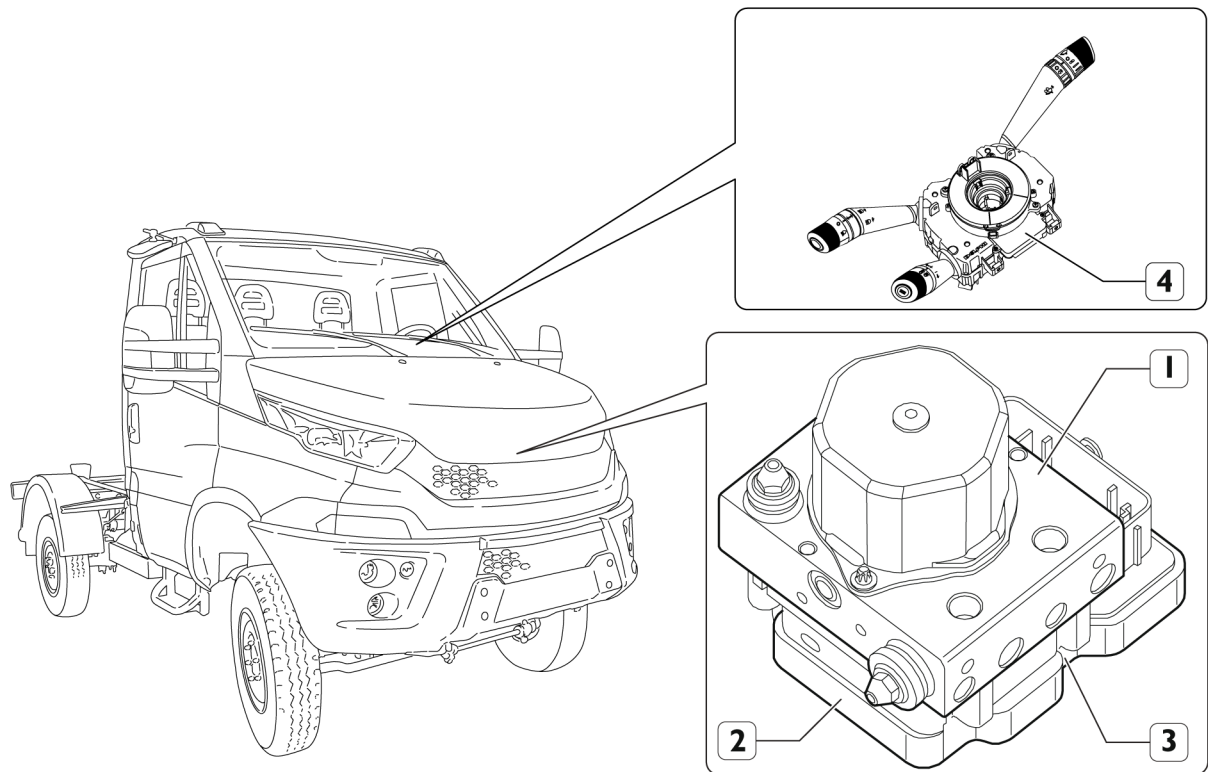

227322 **Figure 10**

- 1. Electrohydraulic braking modulator
- 2. Braking system control unit
- 3. Yaw and acceleration sensor
- 4. Steering angle sensor

To ensure correct programming of the ESP control unit (or Body Computer), the following parameters are important:

- vehicle configuration (van, truck, camper,...);
- wheelbase
- P.T.T.;
- type of suspension;
- type of gearbox/transmission
- wheel circumference;
- retarder (if equipped).

Every variation of one or more of these parameters requires re-programming of the ESP control unit (or Body Computer) or the functional degrading of the system.

The following paragraph describes the main situations that may arise.

Note Reprogramming the control unit or degrading of the ESP system must exclusively be performed by the IVECO Assistance Service.

ESP SYSTEM Derating



- ▶ **The Derating of the ESP system is only possible for certain vehicle categories: for their identification and relative dispositions, refer to Attachment XI of Directive 2007/46/EC - latest version amended. The Derating of the ESP system involves the complete deactivation of vehicle stability control.**

If derating is implemented, functions nonetheless remain active:

- ABS (Antilock Braking System) to avoid wheel locking
- EBD (Electronic Brake Force Distribution) to distribute the braking force between front and rear axles
- MSR (Motor Schlepptomenten Regelung) to control the braking effect of the engine when released
- LAC (Load Adaptive Control) to adapt the extent of braking to the distribution of the load on the vehicle
- HHC (Hill Holder Control) to facilitate breakaway from a standstill in ascent

Variation of P.T.T.

Variations of vehicle P.T.T. must be authorised by IVECO and only in certain special cases is this compatible with the presence of the ESP system.

In the event of compatibility, system management software must be reprogrammed; in all other cases, Derating is compulsory, except as indicated in Attachment XI of Directive 2007/46/EC.

Wheelbase variation

As stated in Chapter 2.4 (► Page 12), the variation of the wheelbase is only permitted upon specific approval of IVECO. In the event of approval the following alternatives may be verified:

a) To values included in the product grid

If the conversion involves a wheelbase value among those in production for the specific vehicle model, ESP system software has to be reprogrammed.

a) To values not included in the product grid

If the conversion involves a wheelbase value NOT corresponding to any of those in production for the specific vehicle model, Derating of the ESP system is compulsory, except as indicated in Attachment XI of Directive 2007/46/EC.

Modification or replacement of suspensions

If an ESP system is present:

- modifications are not allowed of any suspension element;
- total replacement of the suspension is permitted with another suspension already type approved for the specific vehicle model;

Such intervention may only be performed after obtain authorisation from IVECO and require the reprogramming of ESP system software.

Modification or replacement of stabilising bars

The modification or replacement of stabilising bars must be authorised by IVECO and is not compatible with the presence of the ESP system.

Inasmuch, if authorisation is granted, Derating of this system is compulsory, except as indicated in Attachment XI of Directive 2007/46/EC.

Changing tyres

See Chapter 2.14 (► Page 27)



- **It is forbidden to modify the characteristics of the tyres outside the range type-approved by IVECO.**
-

2.16 ELECTRICAL SYSTEM: CURRENT INTERVENTIONS AND DRAWS

For information on work on the electrical system, refer to what is described in Section 5 - Chapter 5.4 .

2.17 PART RELOCATION AND ANCHORAGE OF ADDITIONAL UNITS AND EQUIPMENT

The movement of units (various components, fuel and urea tanks, batteries, spare wheel, etc.) for the installation of equipment is allowed on the condition that:

- the functionality of the unit is not compromised;
- the original type of connection is restored;
- the new placement and distribution of mass is compatible with that originally established.

Horn

The displacement of the horn obligates the body builder for a new approval. Also in the new position, the device must ensure the acoustic performance set by the regulations and must be adequately protected from exposure of weathering and/or soiling. IVECO reserves the right to void the warranty on the moved component.

Wheel holder

Should it prove necessary to modify the position of the spare wheel, then it must be carried out so that its accessibility remains unaltered and that, in any case, a minimum departure angle of 7° is ensured.

For the fastening of the wheel holder bracket and of the relative lifting device, the adoption of a stiffening plate inside or outside the side member is recommended and, where possible, its proximity to a chassis cross member.

The holes to be drilled for the new arrangements should be made on the rib of the side member, according to the regulations contained in Chapter 2.2 (► Page 7) and taking care to use the existing holes as much as possible.

Fuel tank

To obtain indications relating to fuel consumption and tank range, the signals relating to fuel level must be associated with the tank emptying law. This is provided by the Body Computer (see Chapter 5.1 (► Page 5)).

This is not possible when, wishing to increase the vehicle's fuel tank range, a tank of different form is adopted or when another tank is added.

In this case it is the Bodybuilder's responsibility to obtain specific type approval from the designated Authorities (see Chapter 1.5 (► Page 6)) and realize a suitable signal processing method.

Note *In the event of tank replacement the processing logic of the Body Computer must be adjusted.*

The adjustment must be carried out by the IVECO Assistance Service.

2.18 TRANSPORT OF HAZARDOUS MATERIALS (ADR)

The Bodybuilder, upon request, may be given a "Declaration" containing details of the paragraphs of document ECE/TRANS/WP.15/213 that have already been complied with by the vehicle since its origin.

2.19 INSTALLING A RETARDER

Application not provided

2.20 REAR UNDER-RUN PROTECTION (RUP)

The maximum distance between the rear under-run protection device (RUP = Rear Underrun Protection) and the rear-most point of the superstructure is 400 mm, less the deformation observed in the approval phase (on average 10 mm).

If the changes on the chassis require the adaptation of the rear overhang, the under-run protection must be placed by performing the same connection to the chassis as provided in the original version.

In the transformation of the vehicle or in the application of special equipment (e.g. rear tail lifts), it may be necessary to modify the structure of the under-run. The intervention shall not change the resistance characteristics and the original rigidity.

The compliance of the modified device with standards in force must be demonstrated to the competent authorities by appropriate documentation or test certificates.

2.21 REAR MUD GUARDS AND WHEEL ARCHES

On cab version vehicles without rear fenders, the Body builder must implement solutions equal to those provided by IVECO.

For the realisation of the fenders, the wheel arch boxes and the shaping of the superstructure, keep in mind that:

- the free shaking of the wheels must be ensured even in the conditions of use with chains; any indications on limit values can be requested via the Support Service;
- the width of the fender must be greater than the maximum dimensions occupied by the tyres, within the limits set by the regulations;
- the support structure of the fender must have adequate strength and be able to limit the vibrations;
- the connection may be made on the vertical rib of the side members of the vehicle (only using the existing holes) or directly under the applied superstructure (see Figure 11).

The first and the second point are also to be considered in the implementation of wheel arches.

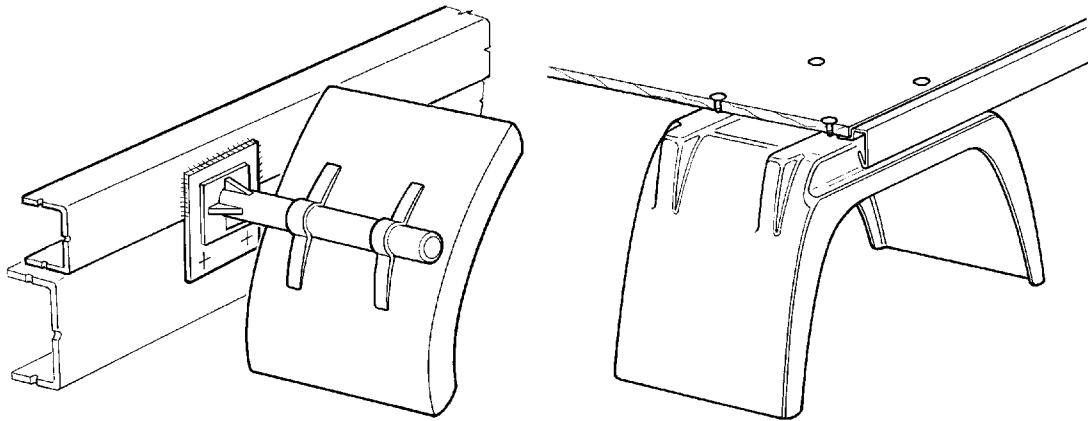

91472

Figure 11

2.22 RAIN FLAP

In cases where legislation requires it and if not present yet, it is necessary to ensure that the complete vehicle is equipped with suitable rain flaps. For installation, it is necessary to comply with the distances required by the laws in force.

2.23 SIDE PROTECTIONS

In some countries, regulations (national or EC) require the application of side protections. Compliance with the required characteristics should be assured by the Bodybuilder who handles completion of the vehicle, if it was not already equipped as such originally (optional setting).

In permanently applied superstructures (e.g. fixed bodies, vans) side protection can be applied on the basis of their structure (e.g. frame of the floor beams), while for mobile superstructures (e.g. tippers) the connection can be made by means of suitable supports on the counter chassis or directly on the chassis. In the latter case, use the existing holes on the vertical rib of the side member as much as possible, in compliance with Chapter 2.2 (► Page 7).

In implementing the outer protection, as required by the regulations (e.g. EC Directive), it is permitted to use either a single section with a surface extending in the vertical longitudinal sections, with pre-set dimensions and distances between them.

The protection must be connected to the support structures in order to be quickly removed or reversed in case of maintenance or repair of the units behind them

SECTION 3

**APPLICATIONS OF
SUPERSTRUCTURES**

Contents	
3.1 CONSTRUCTION OF THE COUNTER CHASSIS	5
Material	5
Sizing of profiles	5
Aluminium counter chassis	7
3.2 ELEMENTS MAKING UP THE COUNTER CHASSIS	8
Longitudinal profiles	8
Cross members	10
3.3 CONNECTION BETWEEN CHASSIS AND COUNTER CHASSIS	11
Choosing the type of connection	11
Connection characteristics	12
Connection with brackets	12
Connections with greater elasticity	13
Connections with clevis fasteners or clamps	14
Connection with longitudinal and transverse sealing plates (rigid junction)	15
3.4 CONTAINER APPLICATION	16
Fixed bodies	16
Tipper bodies	18
3.5 TRACTOR FOR SEMI-TRAILER	19
3.6 TRANSPORT OF INSEPARABLE MATERIALS (TRAILER TRUCKS)	19
3.7 INSTALLATION OF TANKS AND LOOSE MATERIAL CONTAINERS	19
3.8 INSTALLING A CRANE	21
Crane behind cab	22
3.9 INSTALLATION OF TAIL LIFTS	24
3.10 TILT BEDS (BREAKDOWN RECOVERY)	26
3.11 VEHICLES FOR COUNCIL, FIRE SERVICE AND SPECIAL USES	26
3.12 FRONT INSTALLATION OF SNOW PLOUGH ATTACHMENTS	26
3.13 APPLICATION OF A WINCH	26
3.14 SPECIAL OUTFITS	27
Cowl chassis versions	27
Motor home	27

APPLICATIONS OF SUPERSTRUCTURES

Note The following specific instructions complement the regulations contained in Section 1 "GENERAL INFORMATION".

3.1 CONSTRUCTION OF THE COUNTER CHASSIS

The purpose of the counter chassis is to ensure a uniform load distribution on the vehicle chassis and the necessary cooperation with it to the effects of resistance and stiffness, depending on the vehicle's specific use.

Material

In general, if the stresses on the counter chassis are not high, the material for its realisation may have characteristics inferior to those of the frame, notwithstanding the need to have good characteristics of weldability and limits that are not lower than the values **(I)** shown in Table 3.1.

In cases where the stress limits require it (e.g. for crane applications), or if you want to avoid high section height, materials with superior mechanical characteristics may be used. You should, however, keep in mind that the reduction of the time of inertia of the reinforcing section involves bending and higher stresses on the main chassis.

Following are the characteristics of certain materials which were taken into account in some of the applications stated below.

Table 3.1 - Material to be used for the construction of superstructures Std IVECO 15-2110 and 15-2812

Name of steel		Breaking strength [N/mm ²]	Yield stress [N/mm ²]	Elongation
IVECO	Fe 360D	360 (I)	235 (I)	25% (I)
EUROPE	S235J2G3			
GERMANY	ST37-3N			
U.K.	40D			
IVECO	Fe E420	530	420	21%
EUROPE	S420MC			
GERMANY	QStE420TM			
U.K.	50F45			
IVECO	Fe 510D	520	360	22%
EUROPE	S355J2G3			
GERMANY	ST52-3N			
U.K.	50D			

Sizing of profiles

The following table shows the values of resistance modulus W_x for C section profiles recommended by IVECO.

The indicated value W_x refers to the actual section and takes into account the radii of curvature of the section (can be calculated with good approximation by multiplying the value obtained by 0.95 considering the section composed of simple rectangles). Profiles of different section may be used in lieu of those specified, provided that resistance modulus W_x and inertia time J_x of the new C section are not of a lesser value.

Table 3.2 - Profile dimensions

Resistance modulus W_x [cm ³]	Recommended C profile [mm]		
$16 \leq W \leq 19$	80 X 50 X 4	80 X 60 X 4	80 X 50 X 5
$20 \leq W \leq 23$		80 X 60 X 5	
$24 \leq W \leq 26$		80 X 60 X 6	

Resistance modulus W_x [cm ³]	Recommended C profile [mm]		
27 ≤ W ≤ 30		80 × 60 × 7	100 × 50 × 5
31 ≤ W ≤ 33		80 × 60 × 8	100 × 60 × 5
34 ≤ W ≤ 36		100 × 60 × 6	
37 ≤ W ≤ 41		100 × 60 × 7	
42 ≤ W ≤ 45	80 × 80 × 8	100 × 60 × 8	
46 ≤ W ≤ 52	120 × 60 × 6	120 × 60 × 7	
53 ≤ W ≤ 58		120 × 60 × 8	
59 ≤ W ≤ 65		140 × 60 × 7	120 × 70 × 7
66 ≤ W ≤ 72		140 × 60 × 8	120 × 80 × 8
73 ≤ W ≤ 79		160 × 60 × 7	
80 ≤ W ≤ 88		180 × 60 × 8	
89 ≤ W ≤ 93	160 × 70 × 7	180 × 60 × 7	140 × 80 × 8
94 ≤ W ≤ 104		180 × 60 × 8	
105 ≤ W ≤ 122	200 × 80 × 6	200 × 60 × 8	180 × 70 × 7
123 ≤ W ≤ 126		220 × 60 × 7	
127 ≤ W ≤ 141		220 × 60 × 8	
142 ≤ W ≤ 160	200 × 80 × 8	240 × 60 × 8	
161 ≤ W ≤ 178	220 × 80 × 8	240 × 70 × 8	
179 ≤ W ≤ 201	250 × 80 × 7	260 × 70 × 8	
202 ≤ W ≤ 220	250 × 80 × 8	260 × 80 × 8	
221 ≤ W ≤ 224	220 × 80 × 8	280 × 70 × 8	
225 ≤ W ≤ 245	250 × 100 × 8	280 × 80 × 8	
246 ≤ W ≤ 286	280 × 100 × 8		
290 ≤ W ≤ 316	300 × 80 × 8		
316 ≤ W ≤ 380	340 × 100 × 8		
440	380 × 100 × 8		
480	400 × 100 × 8		

While the form of resistance represents a decisive value for the stress of the material, the moment of inertia is important mainly for the flexural hardness and for the quota of the bending moment to be taken, depending on the connection used.

Counter-chassis dimension

In case of elastic connection between chassis and counter-chassis the bending moment M_f must be subdivided proportionately between chassis and counter-chassis at the moments of inertia of the sections:

$$M_f = M_c + M_t$$

$$\frac{M_c}{M_t} = \frac{I_c}{I_t}$$

$$M_c = M_f \cdot \frac{I_c}{I_t + I_c}$$

$$M_t = M_f \cdot \frac{I_t}{I_t + I_c}$$

$$\sigma_c = \frac{M_c}{W_c} \leq \sigma_{amm}$$

$$\sigma_t = \frac{M_t}{W_t} \leq \sigma_{amm}$$

204635

Figure 1

M_f = static bending moment generated by the superstructure [Nmm]

M_c = proportional share of the static bending moment M_f applied to the counter-chassis [Nmm]

M_t = proportional share of the static bending moment M_f applied to the chassis [Nmm]

I_c = moment of inertia of the section of the counter-chassis [mm⁴]

I_t = moment of inertia of the section of the chassis [mm⁴]

σ_c = maximum static stress applied to the counter-chassis [N/mm²]

σ_t = maximum static stress applied to the chassis [N/mm²]

W_c = resistance module of the section of the counter-chassis [mm³]

W_t = resistance module of the section of the chassis [mm³]

σ_{amm} = maximum static stress allowed on chassis [N/mm²] see chapter 2.1, Paragraph "Stresses on the chassis" (► Page 7)

Aluminium counter chassis

When using materials with different characteristics from those of steel (e.g. aluminium), the size and structure of the counter chassis must be appropriately adjusted.

1. When the contribution of the counter chassis is mainly that of providing a uniform distribution of load and the chassis has the fundamental task of resistance, aluminium longitudinal profiles having dimensions similar to those indicated for the steel can be used. Typical examples are fixed bodies, vans and tanks, provided that the supports are continuous and close-up or in the immediate vicinity of the suspension mounts. An exception is made in cases where high stresses on the chassis require relatively large sections of the steel reinforcement, cut-resistant links.
2. When the counter chassis is prompted to make a contribution in terms of strength and hardness (e.g. superstructures with high concentrated loads, tipping bodies, cranes, centre axle trailers, etc.), the use of aluminium is generally not recommended and should be authorised from time to time by IVECO.

Please note that in defining the minimum size of the reinforcement profiles in addition to the limit of the allowable stress for aluminium, reference must be made to the different Elastic Modulus with respect to steel (approx. 7,000 kg/mm² against 21,000 kg/mm² for steel) which involves greater dimensioning of the profiles.

Similarly, when the connection between the chassis and counter chassis is such as to ensure the transmission of the shear stresses (connection with plates), in checking the stresses at the two ends of the individual section, it is necessary to define the new neutral axis for this, on the basis of the different elastic modulus of two materials.

The collaboration requirement for aluminium means, in short, large and not very convenient dimensions.

3.2 ELEMENTS MAKING UP THE COUNTER CHASSIS

Longitudinal profiles

The side members of the added structure must be continuous, extended as much as possible toward the front of the vehicle and towards the rear area of the front spring support; in addition, they must rest on the chassis and not on the brackets.

In order to achieve a gradual reduction of the resistant section, the front ends of the profile must be tapered in height with an angle not exceeding 30° , or another form of equivalent tapering (see Figure 2); the front end in contact with the chassis must be properly coupled, with min. radius of 5 mm.

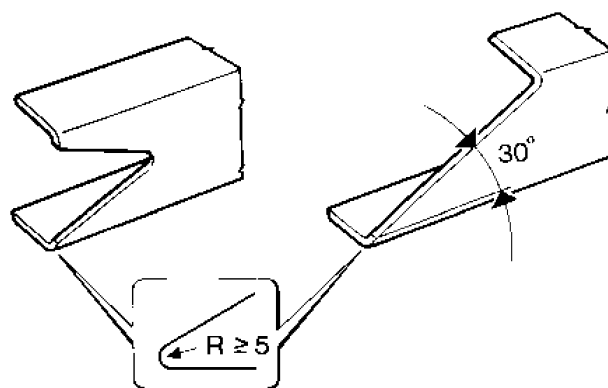

91136

Figure 2

In cases in which the components of the cab rear suspension (e.g. deep cabs) do not allow the passage of the profile in the entire section, this can be realised as in Figure 3. This may require verification of the minimum section of resistance in the presence of high front bending moments (e.g. with a crane behind the cab when operating towards the front of the vehicle) and requires fixing if possible at no more than 250 mm from the front end of the sub-chassis.

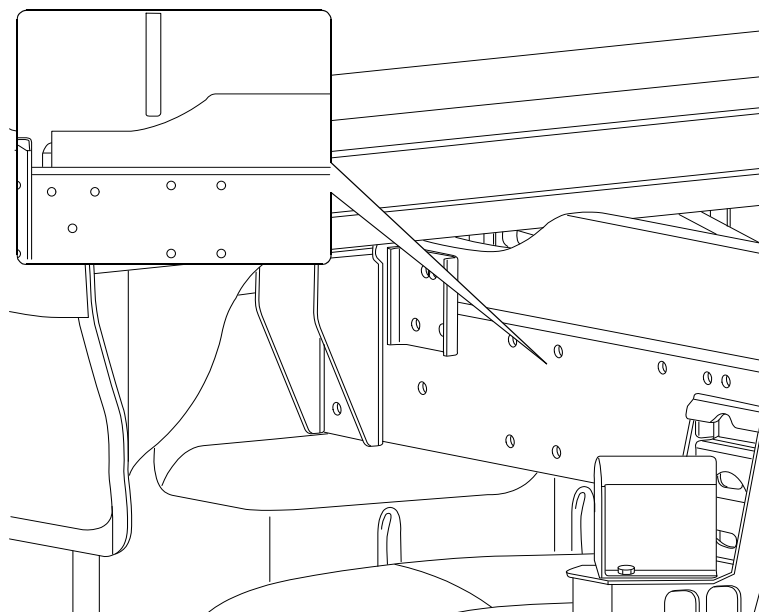

120370

Figure 3

The shape of the profile section is defined taking into account the function of the counter chassis and the type of overlying structure. Open C profiles are advisable when the counter chassis needs to adapt elastically to the vehicle chassis and boxed sections when you require greater stiffness of the assembly.

Care should be taken to achieve a gradual transition from the boxed section to the open section, as in the examples in Figure 4.

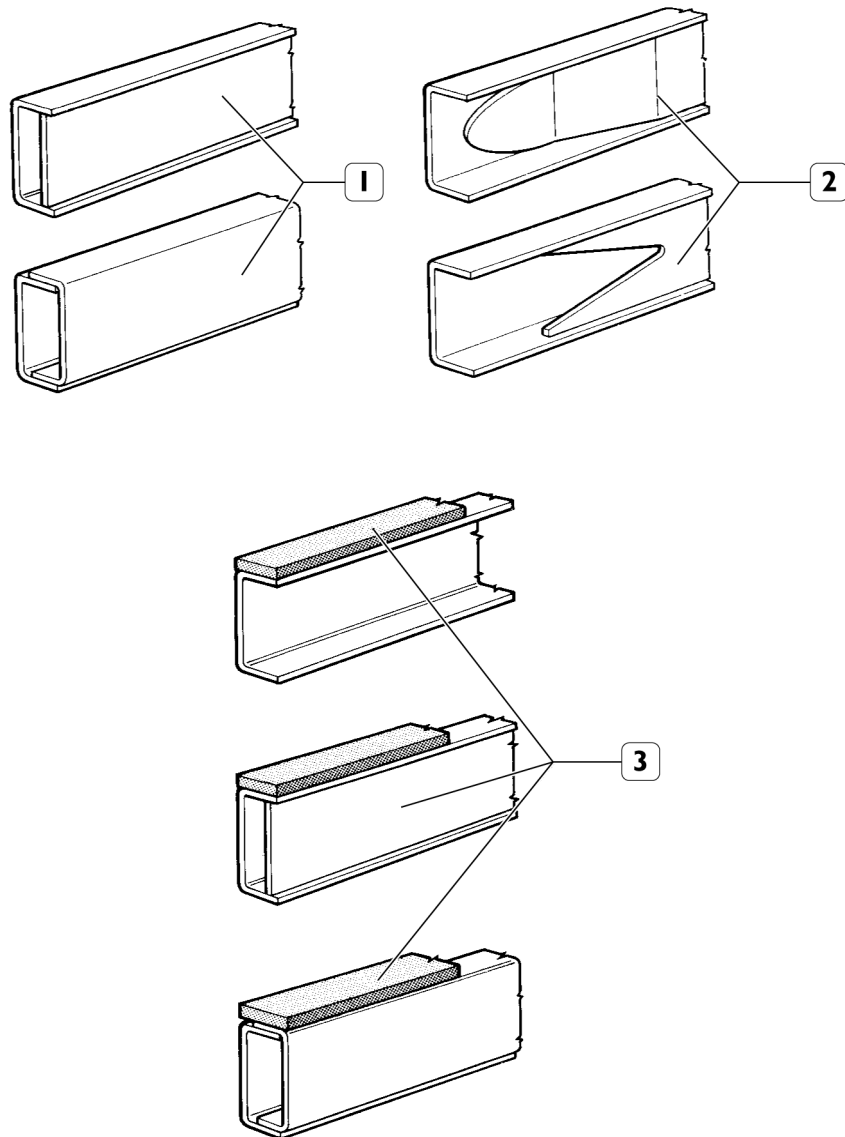

193867

Figure 4

1. Normal boxed profiles
2. Gradual passage from the boxed section to the open section

3. 15 mm lintel (width of the wing of the profile)

It is necessary to create continuity of support between the profiles of the counter chassis and those of the chassis; if this is not obtained, the continuity can be restored by means of interposition of strips of sheet metal or light alloy.

If there is to be a rubber undercrawl element we recommend characteristics and thicknesses similar to those used for normal production (hardness 80 Shore, max thickness 3 mm). Its use can prevent abrasive actions that can cause corrosion in the joining between materials of different composition (e.g. aluminium and steel).

The dimensions prescribed for the side members of the various types of superstructures are the recommended minimum values and, as a rule, are valid for vehicles with wheelbases and rear overhangs provided as standard (see Tables from 3.4 to 3.8). In all cases similar profiles can be used, but with moments of inertia and resistance that are not lower. These values can be obtained from the technical documentation of the profile manufacturers.

Cross members

A sufficient number of crossbars, possibly to be placed in correspondence with the fastening clamps to the chassis, must brace the two sections of the counter chassis.

The crossbars may be open section (e.g. C), or closed section where you would want to impart greater stiffness.

In their connection, suitable gusset plates must be used to give adequate resistance to the connection (see the following Figure on the left). When you want to achieve greater stiffness in the connection, it can be carried out according to the following Figure on the right.

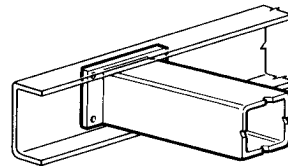
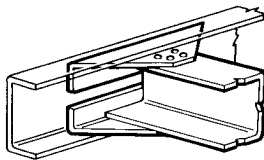

193868

Figure 5

Stiffening of the counter chassis

For some superstructures (e.g. tipping bodies and cranes on rear overhang, superstructures with high centre of gravity), the counter chassis must be stiffened in the rear part.

This can be achieved by increasing the scope of stiffness to obtain:

- boxing the longitudinal sections in the rear area;
- adopting closed section crossbars (see Figure 6);
- applying cross diagonals (see Figure 7);

In general the use of boxed longitudinal sections should be avoided in the front part of the counter chassis.

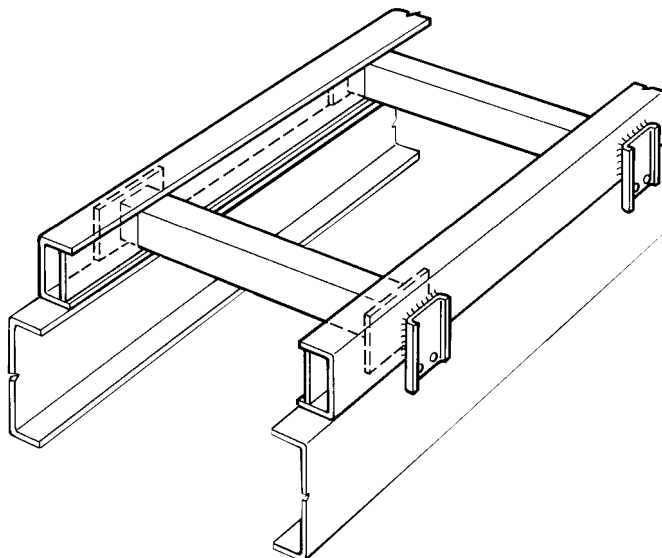

166684

Figure 6

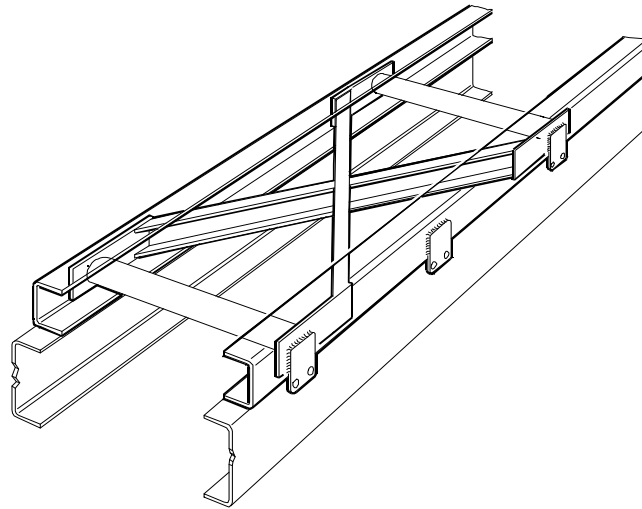

166685

Figure 7

Self-supporting superstructures with counter chassis functions

The interposition of a counter chassis (longitudinal and transverse) can be omitted in the case of installation of self-supporting superstructures (e.g. vans, tanks), or when the underlying structure of the equipment to be installed already has the counter chassis conformation.

3.3 CONNECTION BETWEEN CHASSIS AND COUNTER CHASSIS

Choosing the type of connection

The choice of the type of connection to be used, if not provided by IVECO originally, is very important for the purposes of contribution of the counter chassis in terms of strength and stiffness.

It can be elastic (brackets or clamps) or rigid, resistant to shear stress (plates sealed longitudinally and transversally); the choice must be made according to the type of superstructure to be applied (see Chapters 3.4 to 3.14), evaluating the stresses that the added equipment transmits to the chassis, both in static and dynamic conditions. Number, size and construction of the anchors, reasonably allocated in the length of the counter chassis, must be such as to ensure a good connection between the chassis and the counter chassis.

The screws and the clamps must have material strength class of not less than 8.8, and the nuts must be fitted with systems that prevent unscrewing. The first anchor should be positioned, if possible, at a distance of about 250÷350 mm from the front end of the counter chassis.

The elements for the original connection already existing on the vehicle chassis must be preferred.

The respect of the distance indicated above for the first anchoring must be ensured especially in the presence of superstructures with concentrated loads behind the cab (e.g. crane, front body tilting cylinder, etc.), in order to improve the magnitude of the chassis stresses and contribute more to the stability. Provide additional connections if necessary.

If you have to install a superstructure with features different from those for which the chassis was designed (e.g. a tipping body on a chassis built for a fixed body) suitable connections must be provided (e.g. replacement of brackets with shear resistant plates in the rear area of the chassis).



- ▶ **In anchoring the structure to the chassis, welding must not be performed on the vehicle chassis, nor may holes be drilled into its wings.**

Connection characteristics

Elastic connections (see Figures 8, 9 and 10) allow limited movement between the chassis and the counter chassis; These connections make it possible to consider parallel cooperation of the two resistant sections, where each assumes a share of the bending moment proportional to its moment of inertia.

In the rigid connections (see Figure 11), a single resistant section can be considered for the two profiles, on the condition that the number and distribution of the connections are such as to withstand the consequent cutting forces.

The possibility of establishing a single resistant section between the chassis and the counter chassis allows you to achieve greater resistant capacity compared to the connections with brackets or clamps, obtaining the following benefits:

- lower height of the counter chassis profile to equal bending moment acting on the section;
- greater bending moment allowed, equal to the dimensions of the counter chassis profile,
- further increase in the resistance capacity if materials with high mechanical properties are adopted for the counter chassis.

Connection with brackets

Some examples of this type of connection are shown in Figures 8 and 9.

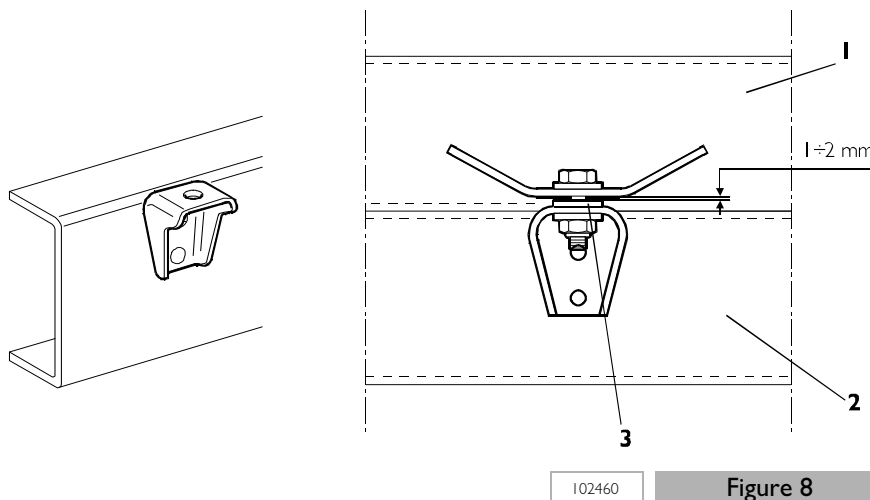

1. Counter chassis
2. Chassis

3. Shims

Figure 8

For the elasticity of the connection it is necessary that, before the closure of the clamping screws the distance between the brackets of the chassis and the counter chassis is 1 ± 2 mm; greater distances should be reduced by means of suitable spacers. At the closure of the screws, brackets must be brought into contact.

The adoption of screws of a suitable length promotes the elasticity of the connection.

The brackets must be fixed to the rib of the side members of the vehicle by means of screws or nails.

In order to better contain the loads in the transverse direction, the brackets are normally applied so that there is a slight protrusion perpendicular to the upper edge of the chassis. If instead the brackets must be applied exactly to the wire, the side guide for the superstructure must be assured with other devices (e.g. using guide plates connected only to the counter chassis, or only to the vehicle chassis, see. Figure 11). When the front connection is elastic (see Figure 9), the lateral containment must be assured even in conditions of maximum torsion of the chassis (e.g. off-road applications).

In the event in which the vehicle chassis is already equipped with brackets for the attachment of a body of a type established by IVECO, these brackets must be used for this purpose. For the brackets applied to the counter chassis or to the superstructure, resistance characteristics not less than those originally mounted on the vehicle should be provided (see Table 2.7 and Table 3.1).

Connections with greater elasticity

When the connection needs greater flexibility (e.g. vehicles with high stiffness of the superstructure such as vans, tanks, etc., used on winding roads or in poor conditions, vehicles for special use, etc.), hardware similar to the type indicated in Figure 9 should be adopted in the area behind the driver's cab. Brackets accompanied by rubber plugs (1) or coil springs (2) should be used.

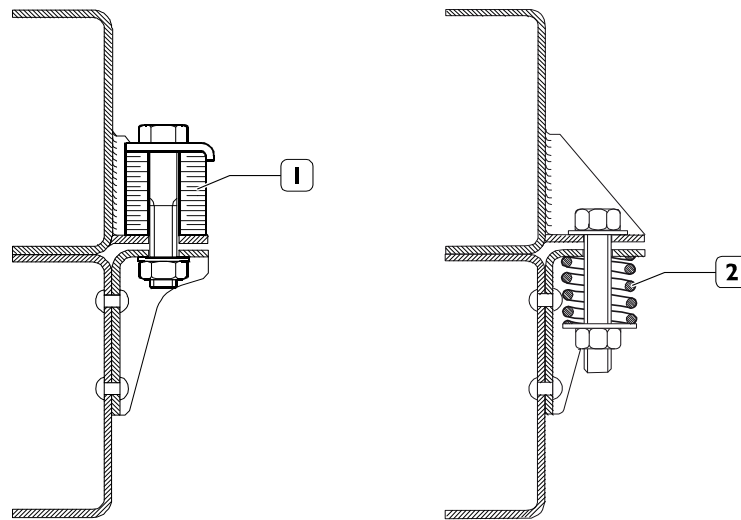

193872a

Figure 9

1. Rubber block

2. Coil spring

Bear closely in mind that:

- the elastic element characteristics should be suited to the stiffness of the superstructure, the wheelbase and the type vehicle use (irregular road conditions);
- stiffness must progressively increase for fixing points closer to the rear part of the chassis;
- the overall connection capacity must also include fixing points resistant to shear stress to be positioned near the rear suspension.

Consequently, the first fixing behind the cab must be made using one of the solutions shown in Figure 9; especially when the vehicle has a long wheelbase, this solution must also be replicated for the next fixing, modifying only the stiffness.

For example, in the case of brackets with rubber pads, elements must be used having the same hardness ($sh = 83$), assembled in dual pairs for the first bracket and single pairs for the next bracket, with M10 screws and tightening torques of di 15-18 Nm.

Also bear in mind that:

- for rubber plugs, use materials that ensure good elasticity over time.
- every solution requires the preparation of appropriate instructions for interval controls and possible resetting of the tightening torques of parts.
- In versions where the vehicle is lifted by hydraulic stabilisers (e.g. cranes, aerial work platforms), limit the collapse of the elastic element to ensure sufficient cooperation of the counter chassis and avoid excessive bending moments on the original chassis.

Also bear in mind that:

1. in the case of superstructures that generate high bending and twisting moments (e.g. a crane behind the cab), the counter chassis must be properly sized to support them;

2. In versions where the vehicle is lifted by hydraulic stabilisers (e.g. cranes, overhead work platforms), limit the collapse of the elastic element to ensure sufficient cooperation of the counter chassis and avoid excessive bending moments on the original chassis.

Connections with clevis fasteners or clamps

Figure 10 shows the main constructions of this type.

In this case the Body builder must interpose a spacer (preferably metal) between the wings of the two side members and in correspondence to the clevis fasteners, in order to avoid the bending of the wings under the pull of the clevis fasteners.

In order to drive and better contain the transverse direction of the structure added to the chassis, this type of fixing can be completed with the addition of plates welded to the counter chassis as shown in Figure 11.

The characteristics of this connection advise against a general integral use on the vehicle; in any case, to give the added structure the suitable containment in the longitudinal direction as well as adequate stiffness, it is necessary to integrate the fastening to the rear part with longitudinal and transverse sealing plates.

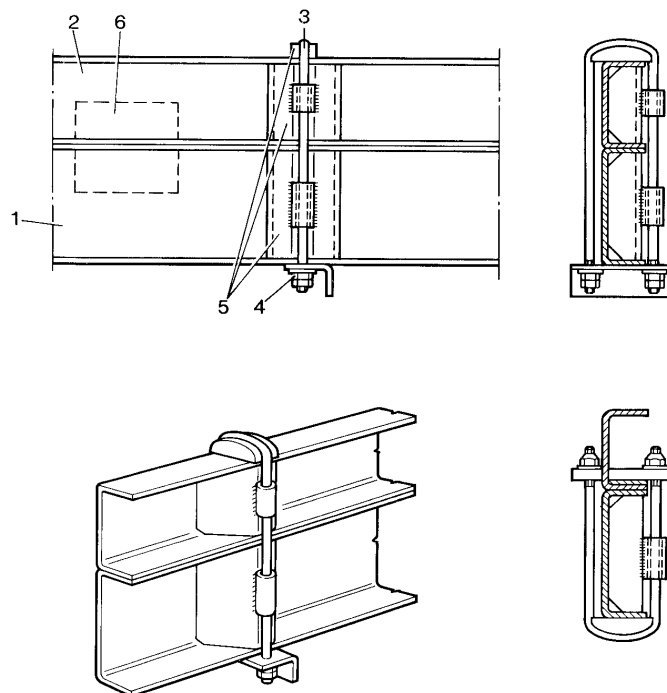

193873a

Figure 10

1. Chassis
2. Counter chassis
3. Clevis fasteners

4. Closure with anti-unscrewing system
5. Spacers
6. Guide plates (if necessary)

Connection with longitudinal and transverse sealing plates (rigid junction)

The type of mounting shown in Figure 11, made with plates that are welded or bolted to the counter chassis and fixed with nails or screws to the vehicle chassis, ensures a good capacity for reacting to longitudinal and transverse thrusts and the greatest contribution to the stiffness of the assembly.

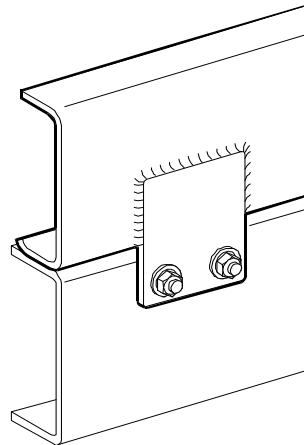

102462 **Figure 11**

For the correct use of these plates, please keep in mind that:

- the vertical rib of the chassis should be fastened only after making sure that the counter chassis is snug against the chassis itself;
- the distribution must be limited to the central and rear area of the chassis;
- the number and the thickness of the plates and the number of fixing screws must be adequate to withstand the bending moments and cutting of the section.

In cases where the superstructure generates high bending and twisting moments on the chassis and its resistant capacity should be increased by adopting a cut-resistant connection between the chassis and the counter chassis, or if you want to contain the height of the counter chassis as much as possible (e.g. centre axle trailers, crane on rear overhang, tail lifts, etc.), use the information supplied in the table below (valid for all models):

Table 3.3

Ratio height/section chassis and counter chassis	Max. distance between the centre lines of the cut-resistant plates [mm] ⁽¹⁾	Models	Minimum characteristics of the plates	
			Thickness [mm]	Dimensions of the screws ⁽²⁾ (min. 3 screws per plate)
≤ 1.0	500	35S15/17, 55S15/17	5	M 12 (2 screws per plate)

⁽¹⁾ The increase in the number of screws for each plate makes it possible to proportionally increase the distance between the plates (a double number of screws may allow a greater distance between the plates). In high stress areas (e.g. the rear spring supports, the tandem axle springs and the air springs), it is necessary to provide a distance between the plates, reduced as much as possible.

⁽²⁾ In the presence of contained thicknesses of the plates of the chassis and the counter chassis, it is advisable to connect by adopting spacer bushes, in order to use longer screws.

3.4 CONTAINER APPLICATION

Dimensions and centres of gravity

Check the correct load distribution and in particular, respect the indications regarding the height of the centre of gravity as provided in Section I using suitable construction precautions and ensure that the transported load has maximum stability while running.

Fixed bodies

The application on vehicles exclusively destined for road use, may be realized by means of a support structure consisting of longitudinal sections and cross members. The minimum Approximate sizes of the longitudinal sections are shown in Table 3.4.

Table 3.4

Models	Minimum reinforcing profile	
	Wheelbase [mm]	Section modulus W_x [cm ³]
35S15/17, 55S15/17	3050, 3400	21

Note For the dimensions of the profiles see Table 3.2.

Fastening is achieved through specially crafted brackets along the vertical rib of the side members (see Figure 12) and, if such connections have not already been specified by IVECO, they must be made according to the instructions in Chapter 3.3 - Paragraph "Connection with brackets" (► Page 12).

If brackets or clamps are used to obtain suitable longitudinal containment, then a rigid connection at the end of the rear overhang is recommended by using plates (see Figure 11).

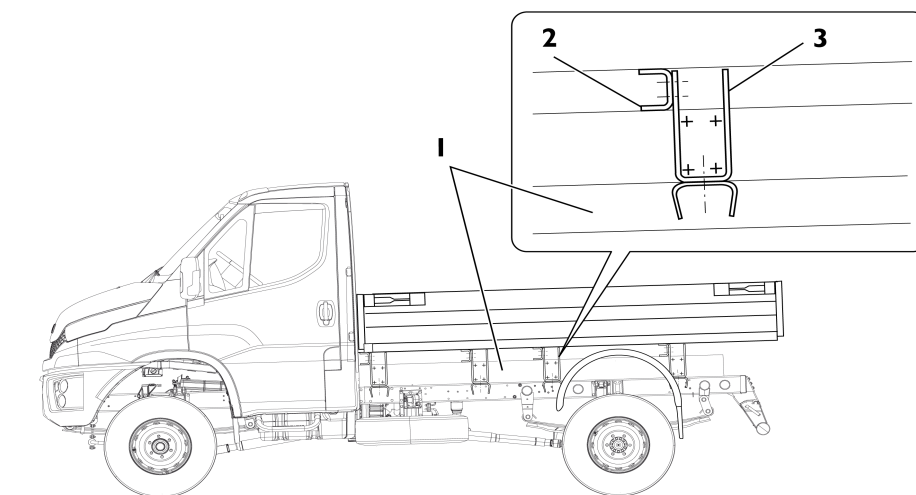

228301

Figure 12

1. Counter chassis
2. Cross members

3. Brackets

In the cases in which the body needs to be kept separate from the chassis so as to avoid excessive overall torsional rigidity, connections are required which utilize box section structures that are fastened to the rib of the side member. Figure 13 illustrates the solution chosen by IVECO and, in particular, it proposes a front part which provides an elastic type constructive solution.

The front wall of the body must have the necessary strength and toughness to support the forces generated by the transported load, in the case of sudden and high decelerations.

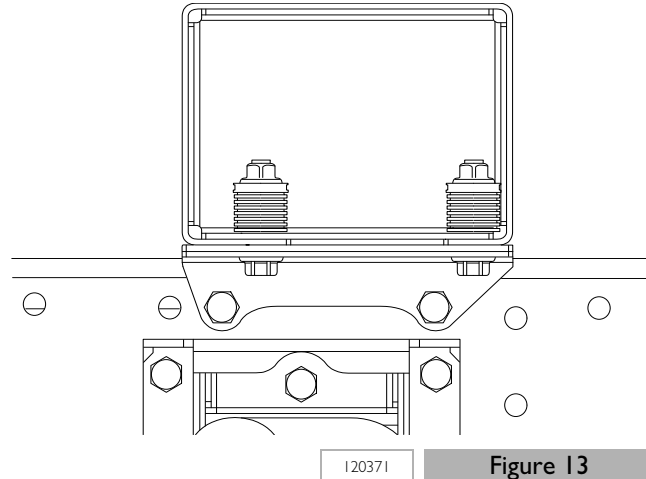

Figure 13

Realization of van boxes

A structure consisting of box section longitudinal and cross members may be used for connection to the chassis of the vehicle. For the longitudinal profiles, refer to the indications in Table 3.4.

Figure 14 shows an example installation where, in order to contain the height of the superstructure, the longitudinal profiles are integrated with cross members and brackets over the entire length.

In this case, the rear wheel arches may be inserted into the base of the structure.

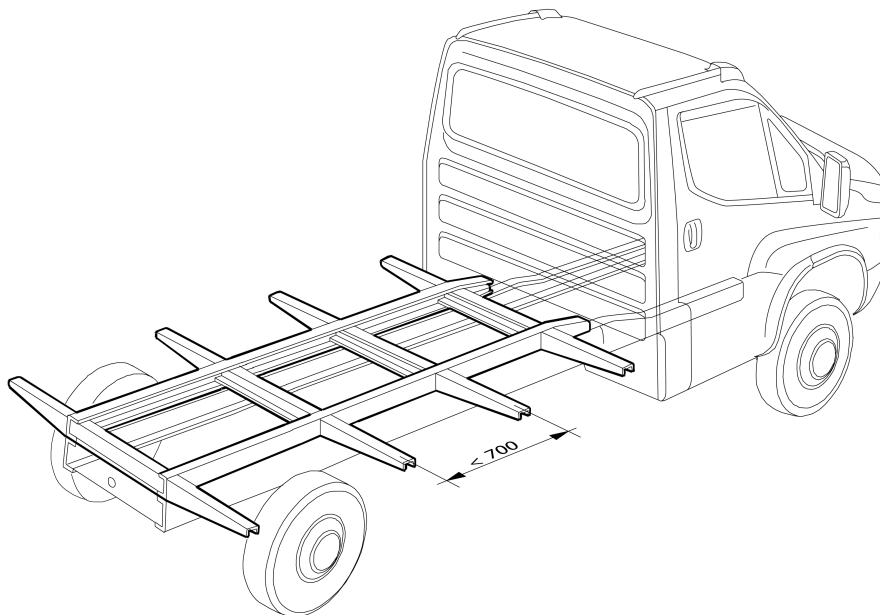

228302

Figure 14

When the floor makes use of cross beams which are no more than 700 mm apart and connected in such a way as to create a sufficiently rigid structure (self-supporting), it may not be necessary to use longitudinal profiles.

The front wall of the van box must have the necessary strength and toughness to withstand the forces generated by the transported load, in the event of sudden and high decelerations.

The mounting of dump bodies and structures having high torsional rigidity in general requires the use of flexible couplings towards the front part of the structure to avoid excessive reduction of the deformation characteristics of the main chassis.

Vans integrated with the cab

The coupling in these cases must be implemented so as to limit the stress transmitted to the vehicle cab.

For couplings and fitting reinforcements, bear in mind that:

- no welding should be performed on the sheet metal of the cab and only mechanical fixture systems should be used;
- the self-supporting structure of the van must not require additional support provided by the cab;
- the parts of the cab affected by the conversion must be protected against oxidation and corrosion (see Chapter 2.2 (► Page 7)).

Tipper bodies

The use of tipper bodies, rear and three sided, generally subjects the chassis to considerable stress.

Therefore, please observe the following indications.

1. The use of a stabiliser bar on all IVECO models for which it is an optional, is recommended.
2. The counter chassis must be:
 - suitable for the type of vehicle and conditions of use,
 - with appropriately sized cross members and side members,
 - with the rear end stiffened with boxing and crossbraces (see Figure 6 and Figure 7). The connections to the chassis must be flexible (brackets or supports) at the front end, whereas the rear section requires stiff connections (cleat plates) (see Figure 11) to allow the added structure to contribute more to the stiffness of the assembly. Omega shelves can be used on vehicles on where these are originally fitted.
3. The rear tipping hinge must be fitted on the counter chassis; its position must be as near as possible to the rear support of the rear suspension. In order not to affect the vehicle's stability during tipping and not to excessively increase the stress on the chassis, the distance indicated in Figure 15 must be respected. Should this not be possible, the counter chassis profiles must be larger than normal and additional reinforcement must be applied to the rear.
4. Great care must be given to the positioning of the lifting device both in terms of providing support of adequate strength and in order to correctly position the mountings. In any case, it is advisable to place the ram to the front of the centre of gravity of the body and payload so as to reduce the extent of the localized load.
5. In rear tipping it is recommended that a stabiliser is fitted to guide the container, particularly when the lifting cylinder is located behind the cab.
6. The lifting device hinge must be mounted on the counter chassis. The useful volume in the body must conform with the maximum permissible load on the axles, to the density of the material to be transported (a density mass of approximately 1600 kg/m³ is to be used for excavated material). In the case of transporting freight with a low density, the useful volume may be increased within the limits established for the maximum height of the centre of gravity of the payload (plus the fixtures).
7. The Body builder must ensure the functioning and safety of all parts of the vehicle (e.g. the positioning of lights, towing hook etc.) and ensure that, following the addition of the structure, vehicle stability is guaranteed during tipping operations.

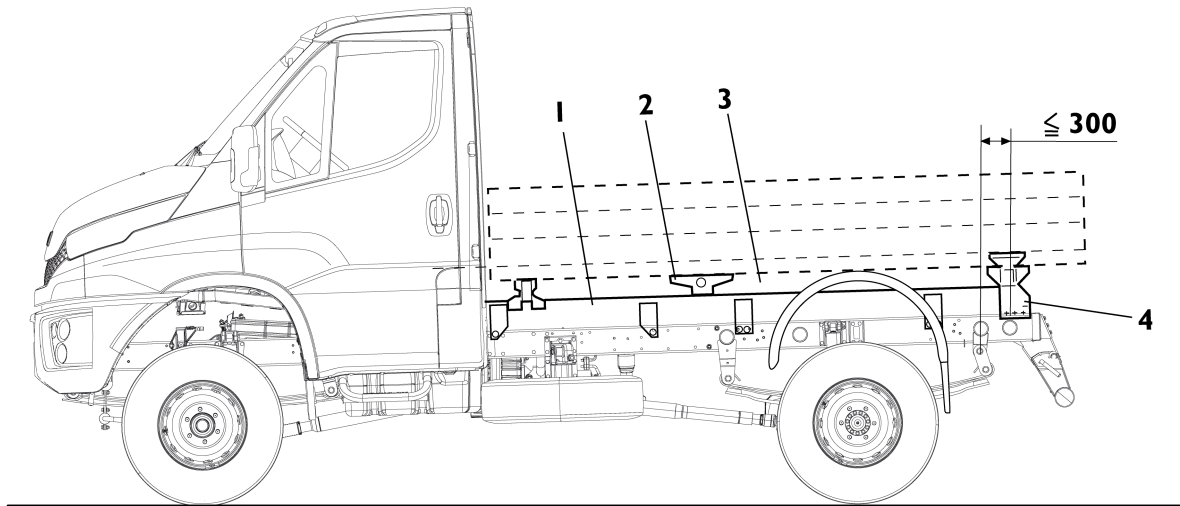

228303

Figure 15

- 1. Counter chassis
- 2. Brackets

- 3. Plates
- 4. Retainer with hinge

Table 3.5

Models	Minimum reinforcing profile	
	Section modulus W_x [cm ³]	Dimensions [mm]
35S15/17, 55S15/17	36	100x60x6

Note For the dimensions of the counter chassis sections see Table 3.2.

3.5 TRACTOR FOR SEMI-TRAILER

Not provided.

3.6 TRANSPORT OF INSEPARABLE MATERIALS (TRAILER TRUCKS)

Not provided.

3.7 INSTALLATION OF TANKS AND LOOSE MATERIAL CONTAINERS

a) Installation with a counter chassis

The installation of tanks and containers is carried out, as a rule, using a suitable counter chassis.

The approximate dimensions of the section to be used for the counter chassis are shown in Table 3.6.

Table 3.6

Models	Wheelbase [mm]	Minimum reinforcing profile	
		Section modulus W_x [cm ³]	Dimensions [mm]
35S15/17, 55S15/17	3050, 3400	21	80x60x5

Note For the dimensions of the profiles see Table 3.2.

The assembly of tanks, or stiff torsional structures in general, must ensure sufficient and gradual flexibility of the chassis, in order to avoid high stress areas.

The use of flexible parts is recommended for the connections between the cistern body and the counter chassis (see Figure I 6) in the front part and rigid supports resistant to the longitudinal and transverse forces towards the rear part.

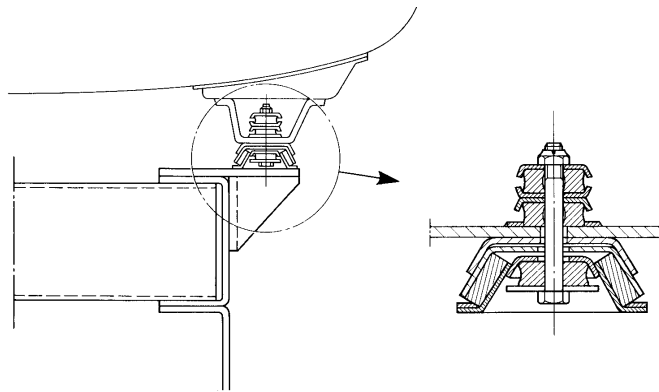

I93895a

Figure I 6

As previously mentioned, the stiff connections positioned in correspondence with the rear suspension mounts are more suitable for transmitting forces directly to the suspension elements; elastic connections are to be arranged near the front suspension rear mount.

If this is not carried out, use suitably oversized longitudinal reinforcement sections with respect to those shown in Table 3.6.

When defining elastic connections, consider the rigidity of the chassis in the area where the connections are to be applied and the type of functions for which the vehicle is intended.

b) Installation without a counter chassis

The application of tanks directly on the chassis is possible under the following conditions:

- the distance between the various rests must be established according to the load to be transmitted (approximately no more than 800 mm);
- the rests must be realized so as to distribute the load uniformly over a suitably wide surface and with appropriate cross bracings (see Figure I 6) to contain the longitudinal and transverse pressures;
- the anchoring points must be of sufficient length (approx. 400 mm – see Figure I 7) and be positioned in the immediate vicinity of the suspension connections.
Specifically, the front anchoring flexibility must be suited to contain the necessary torsional movements of the chassis;
- other anchoring solutions must be authorised by IVECO.

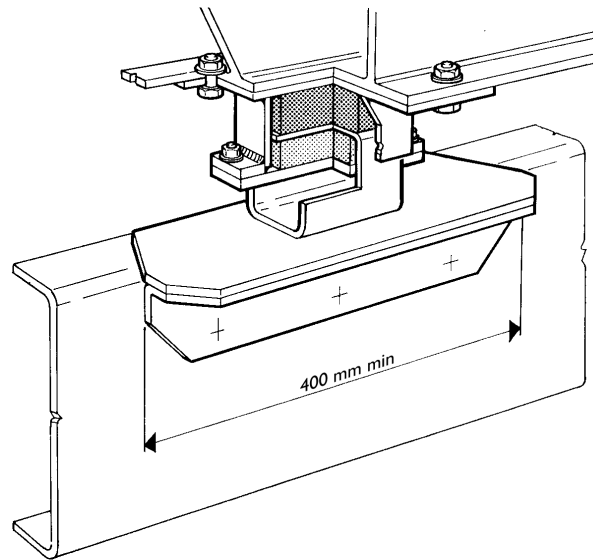

208921

Figure 17

The maximum volume, the degree of filling of the container and the volumetric mass of the transported goods must be defined in observance of the axle weight limits. In the case of tanks and single containers made with separate compartments, the minimum ratio between front axle weight and total fully loaded weight (see Chapter 1.15 (► Page 11)) as well as the maximum axle loads must be observed for all loading conditions.

In consideration of the type of outfit, the use of vehicles equipped with stabilizer bars is recommended and particular attention should be paid to limiting, as far as possible, the height of the overall centre of gravity (see Chapter 1.15 (► Page 11)); use of a vehicle with stabiliser bars is recommended.

In tanks and containers for liquids, transversal and longitudinal partitions are to be used in. In fact, if these are not completely full, the dynamic thrust which the liquid generates while the vehicle is in motion could negatively influence the vehicle's handling and resistance.

Follow the safety laws in force (see Chapter 2.18 (► Page 34)) for containers intended to carry flammable liquids.

3.8 INSTALLING A CRANE

The selection of the crane must be made with due consideration to its characteristics and in relation to the performance of the vehicle.

The positioning of the crane and of the payload must be done within the load limits permitted for the vehicle. Installation of the crane must be carried out in compliance with statutory requirements, national standards (e.g. CUNA, DIN) and international standards (e.g. ISO, CEN) and verifying those required for the vehicle.

While the crane is operating, the stabilisers (hydraulic if possible) must be used and be in contact with the ground.

As a general rule, the installation of a crane requires the use of a suitable counter chassis, the construction of which must take into account the general specifications (see Chapter 3.1 (► Page 5)) and with the dimensions of the sections given in Table 3.7.

The dimensions of the counter chassis resistance modulus refer to the maximum total static moment of the crane (M_G), deduced from the formula shown in Figure 18.

If the vehicle outfitting requires the use of a section with modulus resistance greater than that required for the crane (e.g. tipper), this section may also be considered for the crane.

Special cases in which the moment M_G values correspond to the "E" value in the Table (or for higher values) must be checked individually each time and must receive specific authorisation from IVECO.

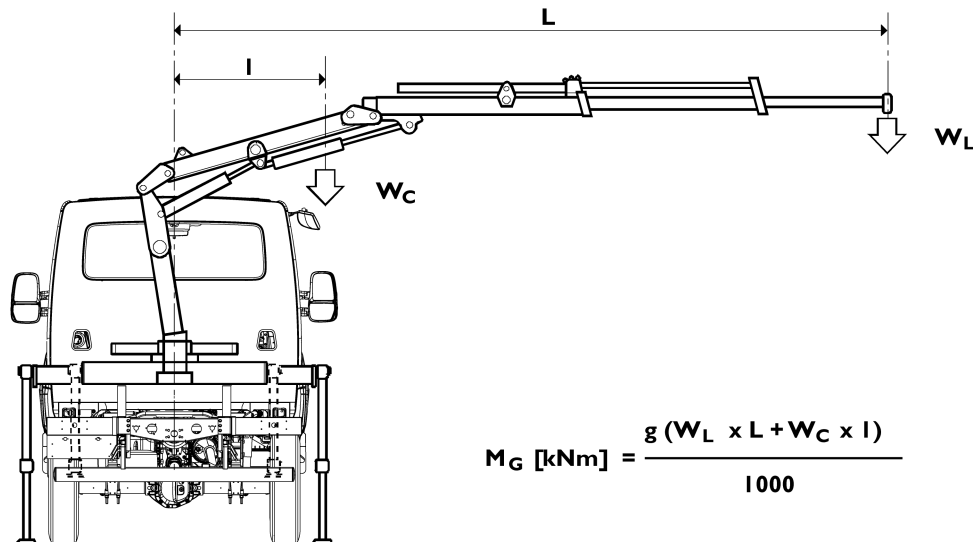

230046

Figure 18

g = acceleration of gravity equals 9.81 m/s^2

W_L = mass applied to crane extremity [kg]

L = horizontal distance between the payload application point W_L and vehicle centre line [m]

W_C = mass of the crane at its centre of gravity [kg]

l = horizontal distance between centre of gravity of crane and vehicle centre line [m]



- ▶ **The Bodybuilder must, case by case, check the vehicle stability and take all necessary precautions for its correct and safe use. The crane manufacturer and the Bodybuilder are responsible for defining the type and number of stabilisers as well as selecting the counter chassis on the basis of the maximum static moment and the position of the crane.**

Crane behind cab

The fastening of the reinforcement sections to the chassis must be carried out using the standard brackets (see Figure 3.19), supplementing them, if necessary, with other fasteners of elastic type (brackets or clamps) in order to keep the flexural and torsional characteristics of the chassis as unchanged as possible. The dimensions of the reinforcement sections to be used for this type of connection are shown in Table 3.7.

On vehicles for road use only, shearing resistant connections may be used for fastening the counter chassis to reduce the counter chassis section height.

The implementation of constant diameter sections for the entire length of the vehicle is recommended.

The section of the crane counter chassis (Figure 19) can be integrated towards the rear end with that envisaged for another possible superstructure; the length " L_v " must in no case be less than 35% of the wheelbase if the superstructure section diameter is smaller.

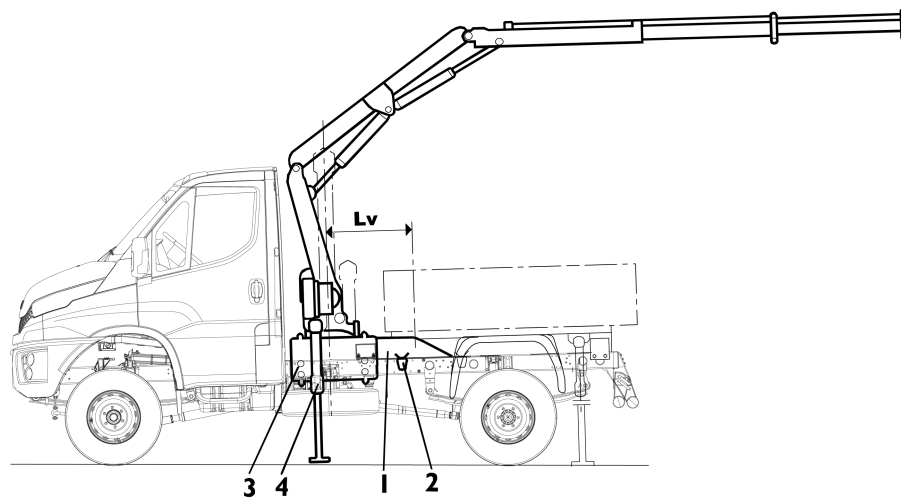

228304

Figure 19

- 1. Reinforcing profile
- 2. Brackets
- 3. Crane connections
- 4. Stabilisers

In installations of cranes on vehicles with deep cab (e.g. 6 + 1), the counter chassis must continue to underneath the cab (see Figure 2), otherwise, depending on the capacity of the crane, it will be necessary to limit the crane's range of rotation, so as not to exceed the permissible bending moment from the chassis.

Elastic connections between chassis and counter chassis (see Figure 8) may be needed to avoid excessive constraint on the chassis torsional movement for application of crane on off-road vehicles on the front and middle parts. The crane is practically connected to the counter chassis only, the dimensions of the longitudinal sections must therefore be suited to withstand the moment induced during use.

The container or equipment must normally be retracted to arrange the crane behind the cab. In the specific case of tipping equipment, particular attention must be paid to arranging the mounts of the lifting device and the tipper rear hinges which must be as retracted as possible.

Table 3.7 - Crane behind driver's cab (counter chassis secured with shelves or flanges)

Model	Wheelbase [mm]	Total torque M_G max [kNm]						
		20	20	30	40	50	60	70
		30	40	50	60	70	80	
		Minimum value of the section modulus of the counter chassis section W_x [cm ³] ⁽¹⁾ with yield point of the material equal to 360 N/mm ²						
35S15/17, 55S15/17	3050, 3400	21	36	57	89	E	E	E

Close the reinforcement section in the crane assembly area.

E = To be checked case-by-case. Send IVECO technical documentation with verification of stress and stability.

⁽¹⁾ When a higher modulus of resistance is required for the superstructure also use the latter for the crane.

Note For the dimensions of the profiles see Table 3.2.

3.9 INSTALLATION OF TAIL LIFTS

Note The installation of tail lifts must be carried out with due regard for the maximum permissible weights on the rear axles of the vehicle and of the minimum load established for the front axle (see Chapter 1.15 (► Page 28)). If this is not possible, the rear overhang will have to be reduced.

The tail lift must be fastened with a structure that ensures appropriate weight distribution, especially in the case of specific outfits with no adequate counter chassis (e.g. box truck bodies, pick-up bodies with cross-members).

The dimensions of the sections to be used can be defined:

- using Table 3.8, in the presence of trucks with rear overhangs as standard;
- using the specifications of Figure 20, in the presence of trucks with non-standard overhangs or specific tail lifts (eg. aluminium) and noting that the flexing moments on the chassis, depending on the board capacities, must be calculated each time;
- using assessments to be carried out each time, in the case of vans, when tail lifts with capacities exceeding 3 kN (300 kg) are used.

To ensure the necessary strength and rigidity, and especially in the case of overhangs exceeding 1200 mm, the connection between the chassis and the counter chassis must be made using shear-resistant plates (spaced no further than 400 mm from one another) in the area of the rear overhang, and must continue up to the front support of the rear suspension (see Figure 20).

Procedure for calculating the chassis bending moment during loading of tail lift

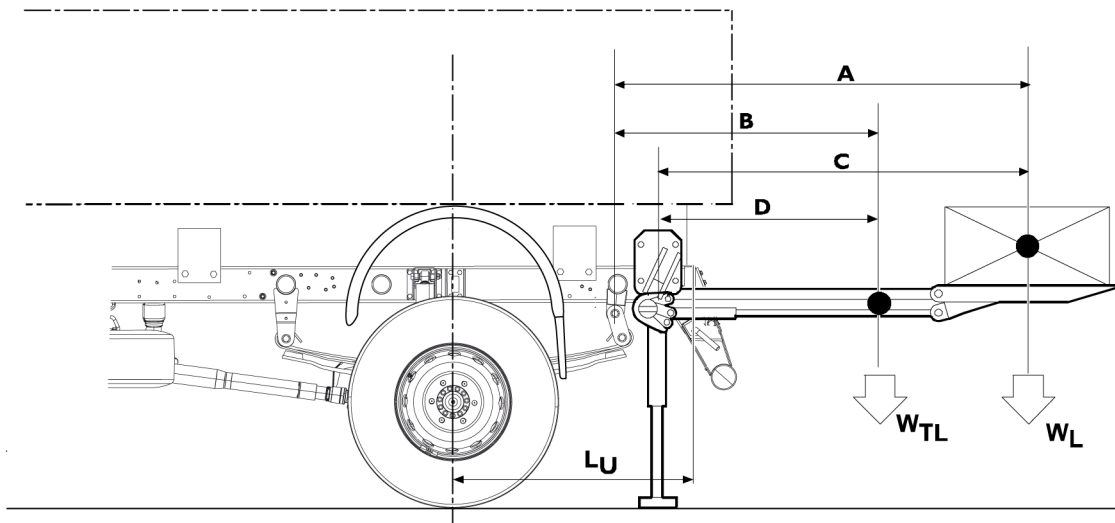

230047

Figure 20

W_{TL} = Weight of tail lift

W_L = Tail lift capacity

The bending moment on the chassis may be obtained using the following ratio:

$$M \text{ [Nm]} = W_L \cdot A + W_{TL} \cdot B \quad \text{for tail lifts without stabilisers}$$

M [Nm] = W_L • C + W_{TL} • D for tail lifts with stabilisers

To compensate for frame flexing, which is inevitable when the tail lift is in operation, the bodybuilder may use reinforcement structures with larger dimensions than those indicated in Table 3.8.

This consideration applies even more in the case of high and non-standard overhangs; in this case the necessity to adopt the stabilisers must also be verified.

Table 3.8 - Installation of tail lifts

Models	Wheelbase [mm]	Tail lift capacity in kN (kg)			
		3 (300)	5 (500)	7.5 (750)	10 (1000)
		Minimum value of the section modulus of the counter chassis section W _x [cm ³] ⁽¹⁾ with yield point of the material equal to 360 N/mm ²			
35S15/17, 55S15/17	3050, 3400	21	21	26 + S	E

E = To check on a case by case basis (send the technical documentation with stress and stability checks).

S = Application of stabilisers necessary.

Note For the dimensions of the profiles see Table 3.2.

The possibility of using materials with superior mechanical characteristics requires verification of the total moment of resistance of the chassis plus counter chassis.



- ▶ **Carefully assess any variations in the stability and attitude of the vehicle caused by suspension compression and chassis flexing during all stages in the operation of the tail lift. Always evaluate whether using stabilisers is advisable even if their use is not rendered necessary by the stresses sustained by the chassis.**

The stabilisers must be attached to the support structure of the tail lift, and should be preferably hydraulically operated.



- ▶ **The stabilisers must be put into operation in all tail lift loading conditions.**

When installing electro-hydraulic tail lifts, ensure that the capacity of the batteries and the power of the alternator are adequate (see Chapter 5.4).

The bodybuilder is also responsible for:

- any modifications to the underrun cross member or the arrangement of another new type (see Chapter 2.20 (► Page 34));
- the observance of the visibility of the rear lights,
- the observance of the overhang angles,
- the positioning of the tow hook,

based on the various national legislation.

3.10 TILT BEDS (BREAKDOWN RECOVERY)

Not provided.

3.11 VEHICLES FOR COUNCIL, FIRE SERVICE AND SPECIAL USES

The outfitting of vehicles for municipal uses (compactor trucks; road cleaning vehicles) in many cases require:

- the realization of a particularly robust counter chassis towards the rear and elastic type connections to the chassis towards the front of the vehicle;
- the vertical placement of the exhaust, behind the cab;
- the adoption of rear suspensions with greater rigidity;
- a new arrangement of the rear lights.



- ▶ **Do not use the reversing light switch, mounted on the gearbox, to activate functions that require increased reliability and safety levels, (e.g. engine stop during reverse, on vehicles for urban waste collection from the personnel present on the rear footboards).**

3.12 FRONT INSTALLATION OF SNOW PLOUGH ATTACHMENTS

The application of a snowplough attachment (blade or ploughshare) to the front part of the vehicle must be carried out using a suitable support structure, appropriately anchored to the core of the chassis side members and in observance of the prescriptions contained in Chapter 2.2 (► Page 7).

Since, when used to remove snow, the vehicle is weighted at the rear and the maximum speed is limited (e.g. 40 km/h), a small increase in maximum axle load may be allowed upon specific assessment and authorisation by IVECO.

It should be possible to use all the elements of the vehicle front panel (e.g. tow-bar, supports for windscreen cleaner); otherwise, equivalent systems must be provided in compliance with the safety requirements.

Observance of the required load must be documented and guaranteed by the company that carries out the installation.

3.13 APPLICATION OF A WINCH

The application of a winch on the vehicle may be carried out on the front part of the chassis (frontal).

The installation must be carried out so as not to alter the correct functioning of the vehicle's assemblies and components, in observance of the maximum permitted axle limits and following the instructions of the winch manufacturer. The fastening of the idler members and assembly, must be carried out in observance of Chapter 2.2 (► Page 7), ensuring that the connection areas are not only reinforced locally (see Chapter 2.17 (► Page 33)), according to the pull of the winch cable and particularly its transverse component, when the traction is oblique.

The installation of a winch in the area behind the cab must allow for the insertion of an auxiliary frame, of suitable dimensions and structure (crossbars and diagonals for stiffening) for the winch capacity.

In the event of winches:

- hydraulically controlled: previously installed hydraulic pumps can be used for other services (tipping bodies, cranes, etc.);
- mechanical: for transmission of the control it is necessary to follow the indications contained in Chapter 4.1 (► Page 5) and 4.2 (► Page 7);
- with worm screw control: the dimensioning of the drive parts must take into account the low efficiency of controls of this type;
- electric: these are used for low power applications of brief duration, given the limited capacity of the vehicle battery and alternator.

3.14 SPECIAL OUTFITS

The body builder must ensure compliance of operations carried out with legal requirements, especially in the case of configurations for the transport of persons.

Cowl chassis versions

They are made specifically for the installation of special bodies or equipment (shop vans, motor homes, etc.).

The indications and precautions shown on the technical documentation (chassis diagram) provided by IVECO must be carefully respected.

Motor home

Mass limits applicable to single axles must be strictly adhered to, as well as the total limit, keeping in mind a sufficient load margin in addition to the number of people expected:

- baggage, tents, sporting equipment;
- water tank, sanitary facilities;
- gas cylinders, etc.

It is necessary to ensure that the load to be transported can be placed in specific compartments, with appropriate safety margins and providing suitable directions.

Special attention must be given to the construction of compartments for gas cylinders, which must be built in compliance with specific regulations in force and adopting the necessary safety precautions.

For repair operations on the rear overhang, see the instructions in Chapter 2.5 .

SECTION 4
POWER TAKE-OFFS

Contents

4.1	GENERAL SPECIFICATIONS	5
	Type of use	5
	PTO transmission	6
4.2	POWER TAKE-OFF ON THE GEARBOX	7
	Data of power take-off on the gearbox	7
	Direct application of pumps on the gearbox PTO	8
4.3	POWER TAKE-OFF FROM TRANSFER BOX	8
	Direct application of pumps on the transfer box PTO	9
4.4	POWER TAKE-OFF FROM DRIVE LINE	11
4.5	POWER TAKE-OFF FROM ENGINE	11
4.6	PTO MANAGEMENT	12
	After-sales PTO installation	13
	PTO management on gearbox	13

POWER TAKE-OFFS

4.1 GENERAL SPECIFICATIONS

Different types of power take-offs (PTO) for motion withdrawal can be mounted for operating auxiliary units. Depending on the type of use and performance required, the application can be fitted to:

- the gearbox;
- on the transfer box.

The characteristics and performances are given in the paragraphs which follow and in the relevant documentation which will be supplied upon request.

For the definition of the power necessary for the apparatus to be controlled, particularly when the values requested are high, the absorbed power should also be considered during the drive transmission phase (5 to 10% for the mechanical transmissions, belts and gears, and greater values for the hydraulic controls).

The choice of the transmission ratio for the power take-off should be made so that the power absorption occurs in a flexible engine operating range; low speeds (below 1000 rpm) must be avoided to prevent irregular running.

The available power can be calculated in relation to the power take-off speed and the established torque.

$$P \text{ [CV]} = M \cdot n \cdot i / 7023$$

$$P \text{ [kW]} = M \cdot n \cdot i / 9550$$

P = Available power

M = Torque permitted for the power take-off

n = Engine revolutions per minute

i = Transmission ratio = PT output rpm / engine rpm

Type of use

The maximum torque take-off values refer to continuous usage of up to 60 seconds.

Torque take-off values exceeding the maximum values indicated for occasional, limited usage (less than 30 s), must be approved on a case by case basis in relation to the type of application.

In the case of continuous usage exceeding 60 seconds, where the function is comparable to that of a stationary motor, the necessity of reducing torque take-off in relation to other, peripheral conditions (such as engine and transmission cooling necessities) must also be evaluated.

In the case of continuous usage which may lead to high oil temperatures, it is advisable to contact the PTO supplier to determine whether the installation of a dedicated external oil circuit kit is necessary.

The scheduled take-off values are also applicable for uses which do not involve large variations of torque either in frequency or magnitude.

In other cases, to avoid overload (e.g hydraulic pumps, compressors) it may be necessary to include the application of devices such as clutches or safety valves.



- ▶ **During prolonged use, the gearbox oil temperature must not exceed 110 °C and the water temperature must not exceed 100 °C.**



- ▶ **Not all types of power take-offs are suitable for continuous use; always follow the specific instructions for the power take-off during operation (working times, breaks etc.).**

PTO transmission

In full compliance of the Manufacturer's transmission specifications, the kinematic forces from the power take-off to the relevant apparatus should be carefully considered (angles, rpm, moment) during the design phase as well as the dynamic behaviour in the installation phase.

This means that:

- the dimensions should take into consideration the forces which might occur under maximum power and torque conditions;
- to ensure effective kinetic forces, the shaft ends must be at the same angle (see Figure 1), and this angle must not exceed 7°;
- solution Z is preferred to solution W due to the lower loads on the bearings of the power take-off and the equipment being driven. When it is necessary to obtain a different transmission line with spatial inclinations according to angle ϕ (as shown in Figure 2), it is important to remember that the kinetic forces of the assembly can only be ensured if the intermediate section has forks offset by the same angle ϕ and if equal conditions are respected between the angles at the extremities X_1 and X_2 .

For transmissions employing multiple sections, please refer to the indications provided in Chapter 2.8 (► Page 17).

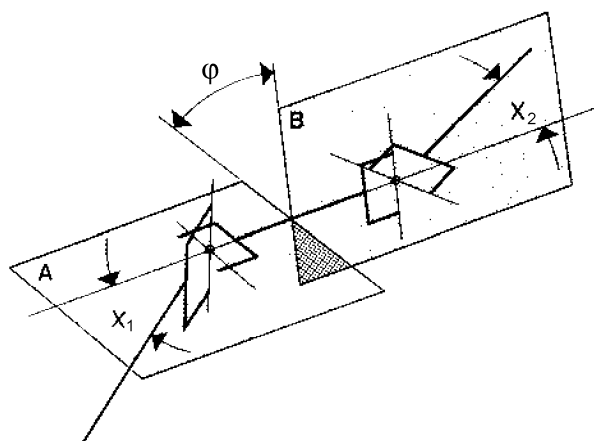
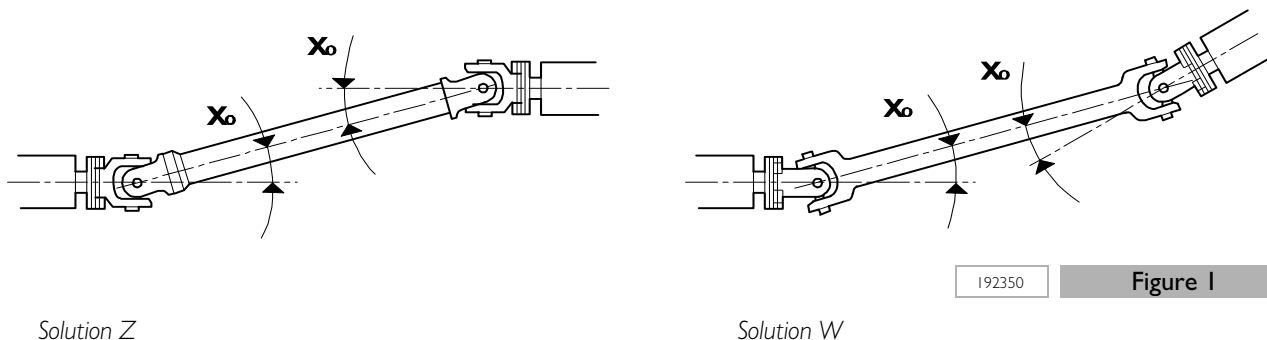

91523 **Figure 2**

4.2 POWER TAKE-OFF ON THE GEARBOX

Drive may be taken from the layshaft via flanges or fittings located to the rear side or lower part of the gearbox.

Table 4.1 shows available torque levels and the ratios between output rpm and engine rpm for the different types of IVECO optional gearbox/PTO combinations.

IVECO must authorize high torque take-offs for sporadic use, according to the type of use.

The PTO must normally be used with the vehicle at a standstill and must be engaged and released with the clutch disengaged so as to avoid excessive stress on synchronisers.

When the PTO is used with the vehicle in motion, no gearshift must be carried out.

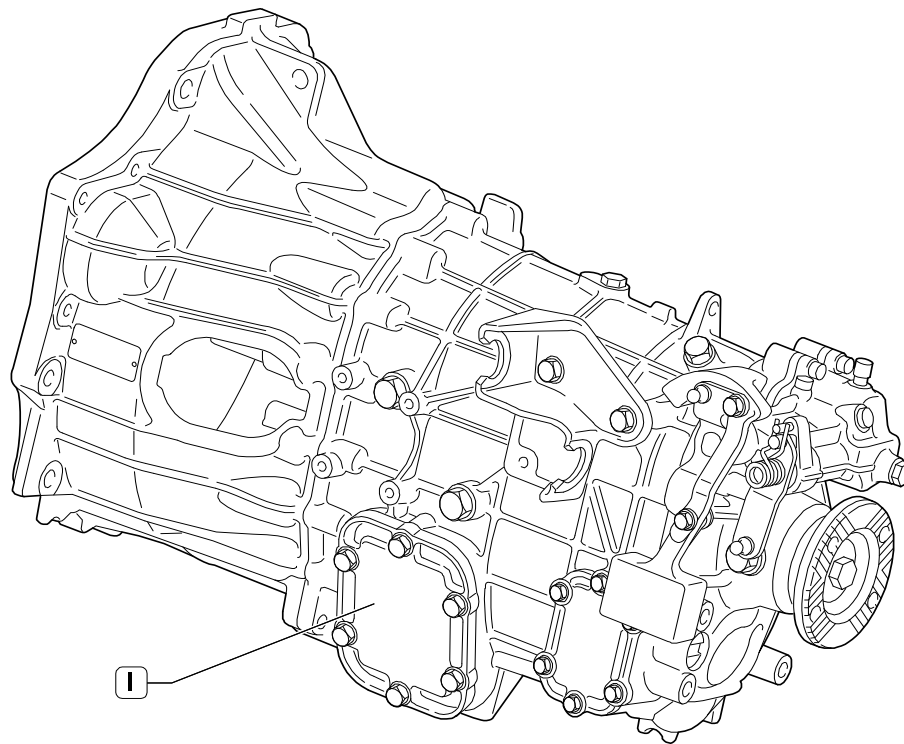

166057 **Figure 3**

- I. Cover for power take-off pre-installation

Data of power take-off on the gearbox

The installation of a P.T.O. after the production of the vehicle requires some intervention on the electrical system. Therefore, before proceeding, please carefully read Chapter 4.6 .

Table 4.1

Gearbox	Position ⁽¹⁾	Output ⁽¹⁾	Direction of rotation ⁽²⁾	Maximum torque C_{max} [Nm] ⁽³⁾	PTO ratio
2840.6	Left side	Rear	Clockwise	180	1,04

⁽¹⁾ With respect to the direction of travel

(2) Frontal view of the PTO output

(3) The maximum available torque refers to a speed of 1500 rpm in output from the PTO. For higher speeds, proportionally reduce the available torque value



- ▶ **IVECO reserves the right to void the guarantee on the gearbox if malfunctions are due to the PTO and, in that case, if the PTO installed by the bodybuilder has performance other than those indicated in Table 4.1.**

Direct application of pumps on the gearbox PTO

When the application of pumps of other equipment is carried out directly from the power take-off, without the use of intermediate shafts and after checking that the size of the pump permits margins of safety with the chassis and engine unit, the static and dynamic torques exerted by the mass of the pump and by the power take-off should be checked for compatibility with the resistance of the walls of the gearbox.

Furthermore, the value of the additional masses must be verified with regard to the inertial effects in order to avoid the induction of resonance conditions in the engine unit within the field of operational engine.



- ▶ **Observe values in Table 4.1 for torque take-offs. During prolonged use, the gearbox oil temperature must not exceed 110 °C and the water temperature must not exceed 100 °C. Not all types of power take-offs available on the market are suitable for continuous use; always follow the specific instructions for the power take-off during use (working times, breaks etc.).**

The power take-off provided by IVECO includes a flange for the direct installation of pumps with 4-hole UNI attachment.

The output is formed by a 21 ISO 14 splined shaft.

4.3 POWER TAKE-OFF FROM TRANSFER BOX

It is possible to consider the assembly of a rear power take-off on the transfer box. IVECO provides for the adoption of specific optionals, contained in Table 4.2.

Table 4.2

OPT	type	Figure	Coupling flange	Drive transmission	Maximum output torque C_{max} [Nm] P_{max} [CV] ⁽¹⁾	Gear shift	Transmission ratio
8693	2 right	4	Assembly 2	Grooved hole DIN 5482 B35x31	C_{max} 150 P_{max} 40	1	5.375
8694	3 right	5	Assembly 3	Grooved hole DIN 5482 B35x31		2	3.154
8695	ISO	6	ISO 4 holes	Grooved hole DIN ISO 14 5482 B35x31		3	2.041
						4	1.365
8696	Flange	7	–	SAE 1400 4xM12		5	1
						6	0.791
						RM	4.838

(1) The maximum output torque values refer to an engine speed of 1900 rpm with fifth gear. For different engine speeds or gears, make sure that the maximum declared output torque and power values are not exceeded. The power take-off on the transfer box may be used with a stationary or moving vehicle.

Direct application of pumps on the transfer box PTO

When the application of pumps or other electrical utilizer devices is performed directly on the power take-off (without intermediate shafts) then, after having checked that the pump dimensions allow safety margins with the chassis and the reduction unit (cross members, propeller shaft, etc.), it is advisable to check that the static and dynamic torques exerted by the mass of the pump and of the power take-off are compatible with the wall strength of the transfer box.

Furthermore, the value of the additional masses must be verified with regard to the inertial effects in order to avoid generating resonance conditions within the field of engine operation.



- For continuous uses of the power take-off, check that the oil temperature of the reduction unit does not exceed 110 °C and that the engine coolant temperature does not exceed 100 °C.

Flange type - Assembly 2

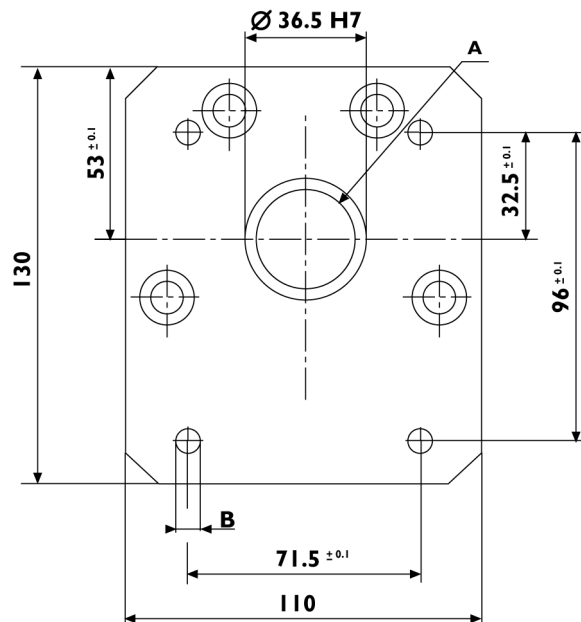

227317

Figure 4

A. Female grooved profile DIN 5482 A35x31

B. 4 holes M8x20

Flange type - Assembly 3

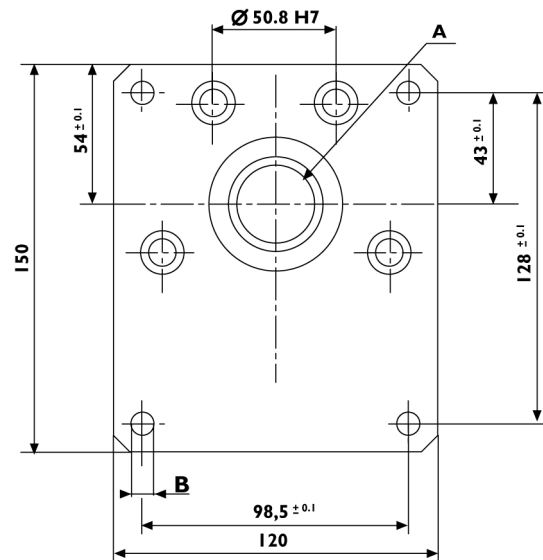

227318

Figure 5

A. Female grooved profile DIN 5482 A35x31

B. 4 holes M10x25

Flange type - ISO 4 holes

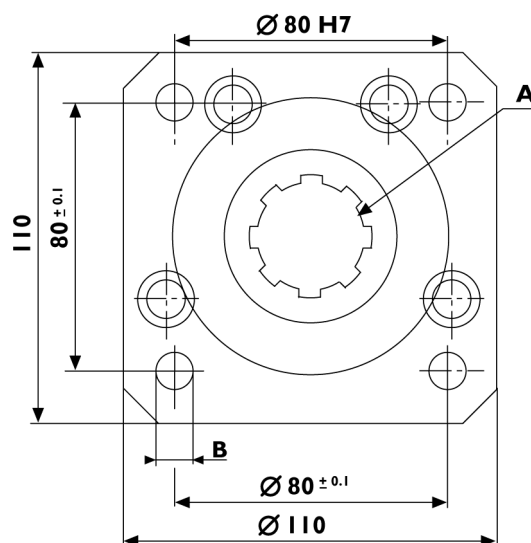

227319

Figure 6

A. Female grooved profile DIN ISO 14 B8x32x36

B. 4 holes prof. 25

Flange type - SAE

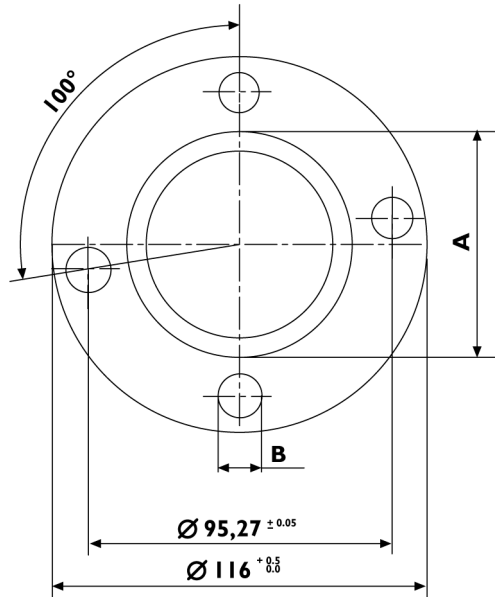

227320 **Figure 7**

A. $\varnothing 69.85$ H9 prof. 2.5

B. 4 holes $\varnothing 12.25$

Engagement and disengagement of the power take-off are controlled by a solenoid valve that supplies oil to a simple effect actuator.

These functions are controlled by a push-button on the dashboard.

4.4 POWER TAKE-OFF FROM DRIVE LINE

Not available on Daily 4x4.

4.5 POWER TAKE-OFF FROM ENGINE

Not available on Daily 4x4.

4.6 PTO MANAGEMENT

Originally the vehicle may be alternatively equipped with:

a) PTO on gearbox pre-installation (opt. 77910)

This pre-installation consists of:

- cover on gearbox (see Figure 3);
- bonnet cable equipped with supplementary connection dedicated to the PTO signals.

b) PTO on gearbox pre-installation (opt. 77910) and Expansion Module (opt. 8657)

The Expansion Module is an electronic interface designed to manage certain types of configurations (additional lights, alarms, "after market" PTOs, etc.) and is pre-installed on the vehicle.

Note For the description of the features and ways of using the Expansion Module, please consult the specific IVECO manual.

c) Original equipment PTO on gearbox (opt. 75076) and Expansion Module (opt. 8657) and/or PTO on transfer box (for opt. see Table 4.2).

In this case the PTO actuation switches are fitted on the dashboard (see Figure 8).

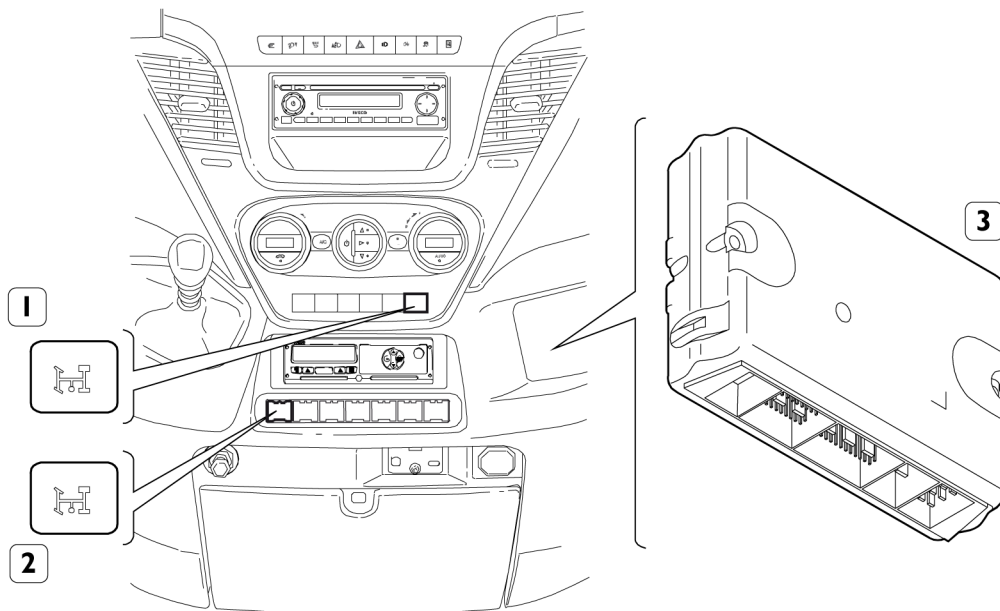

228699

Figure 8

1. PTO control switch on transfer box
2. PTO control switch on gearbox
3. Expansion Module

The arrangement of the switches depends on the optionals installed on the vehicle

After-sales PTO installation

If an after-sales PTO is to be installed, then it is necessary to check the following:

- that the vehicle is equipped with the Cruise Control opt.;
- obtain approval for the intervention from IVECO and any specific instructions that may be required.

Note *The after-sales installation of a PTO means, once installation is complete, referring to IVECO Assistance Service to update the ECU software through the teleservice.*

PTO management on gearbox

Note *For instructions on how to engage and disengage the PTO on the gearbox, in addition to its “stationary” or “not stationary” configuration, please consult the Use and Maintenance Manual.*



- ▶ **For safety reasons, when the non-stationary PTO is engaged, gear changes are not possible and the vehicle should not exceed a speed of 20 km/h.**



- ▶ **It is necessary to switch off the PTO when a torque withdrawal is not in progress.**



- ▶ **The PTO must be disengaged before turning off the engine using the bodybuilder connector. In any case, the engine cannot be restarted from the connector while the PTO is still connected.**

PTO management on transfer box

The engagement and disengagement of the power take-off are controlled by a solenoid valve.

Engagement:

- stop the vehicle and maintain the engine at idle speed;
- check that the lever of the half gears of the reduction unit (B) and of the gearbox gears are in neutral and that the handbrake is engaged;

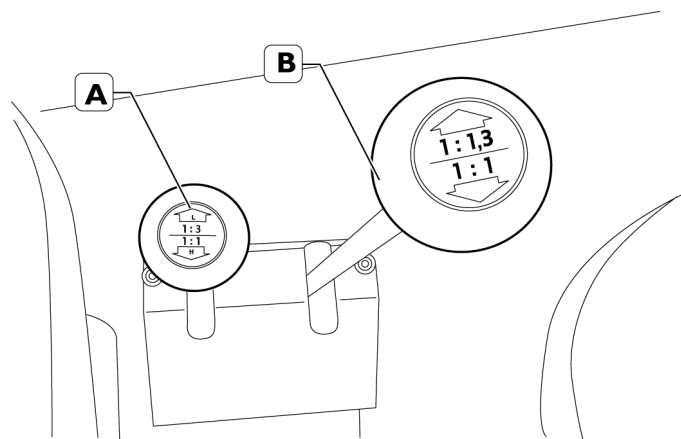

227329

Figure 9

- fully depress the clutch pedal;
- press and release the push-button I in Figure 8, which controls engagement of the PTO on the reduction unit;

- the warning light starts flashing;
- the PTO is engaged when the warning light stops flashing and stays on and a short sound is heard;
- engage the gear of the gearbox.

Disengagement:

- stop the operation of the equipment;
- depress the clutch pedal
- put the gearbox in neutral;
- press and release the push-button 1 in Figure 8;
- when the warning light goes out, the PTO is disengaged;
- release the clutch pedal.



► **It is necessary to switch off the PTO when a torque withdrawal is not in progress.**

Adjust the engine speed for removing the engine

The engine management control unit provides a function which enables simultaneous adjustment of the engine revs and the power take-off by operating the Cruise Control lever (see Figure 10)

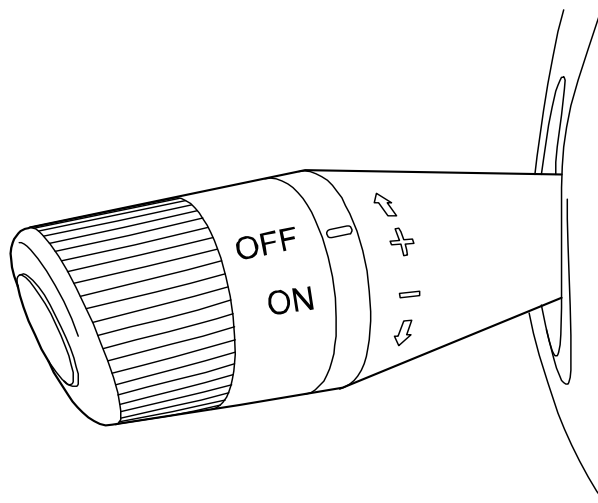

208927

Figure 10

The control unit is also able to perform the control of the set revolutions and maintain or restore balance depending on the applied load.

Note *The adjustment of engine speed through Cruise Control (Working Engine Speed Demand) may only be performed with the vehicle stationary or when the vehicle speed is less than between 10 and 20 km/h, depending on the vehicle version.*

After turning the selector of Figure 10 in the ON position, actuating in the direction + or - makes it possible to increase or decrease the number of revolutions in two ways:

- a) with steps of 50 rpm if the lever is operated for between 0.5 and 2 seconds;
- b) with a ramp of 400 rpm for each second of continuous activation of the lever, beyond 2 seconds.

It is possible to store a new speed (with PTO on) by pressing and holding the RESUME button for at least 5 seconds.

With Cruise Control activated, it is possible to return to the minimum engine speed condition (setting cancelled) by placing the selector shown in Figure 10 on OFF, or by pressing the brake pedal or clutch pedal.

Note *To manage engine speed control, requested torque and other parameters programmable on the Expansion Module, consult the specific IVECO manual.*

Multiple State Switch

It is an alternative method of controlling the number of engine revs. with the power take-off engaged, and is available through the 12-way connector 72075A.

To obtain this function it is necessary to realize the circuit outlined in Section 5, Paragraph "12-pin connector 72075A (►► Page 12)", Note ⁽³⁾.

SECTION 5
**ELECTRONIC
SUB-SYSTEMS**

Contents

5.1	ELECTRONIC SYSTEM	5
5.2	BODYBUILDER CONNECTORS	6
	Connector 61071A, blue, 20-pin	7
	Connector 72075A, black, 12-pin	12
5.3	ELECTRONIC CONTROL UNITS	18
	Precautions to be used with electronic control units installed	18
	Disconnecting electronic control units	19
	Repositioning electronic control units	20
5.4	ELECTRICAL SYSTEM: CURRENT INTERVENTIONS AND DRAWS	20
	Ground points	22
	Electromagnetic comparability	27
	Reception/transmission systems	29
	Additional equipment	34
	Drawing current	38
	Additional circuits	41
	Modifying wheelbase and overhang	43
	Trailer setup	43
	Side Marker Lamp installation	45
	Reverse gear signal	46
	Antitheft system	47

ELECTRONIC SUB-SYSTEMS

5.1 ELECTRONIC SYSTEM

Below is the location of the ECUs and connectors that can be installed on the vehicle.



► **It is not permitted to connect devices or electrical circuits directly to the control units described below. Only the connectors listed in the following paragraphs may be used.**

Location of control units

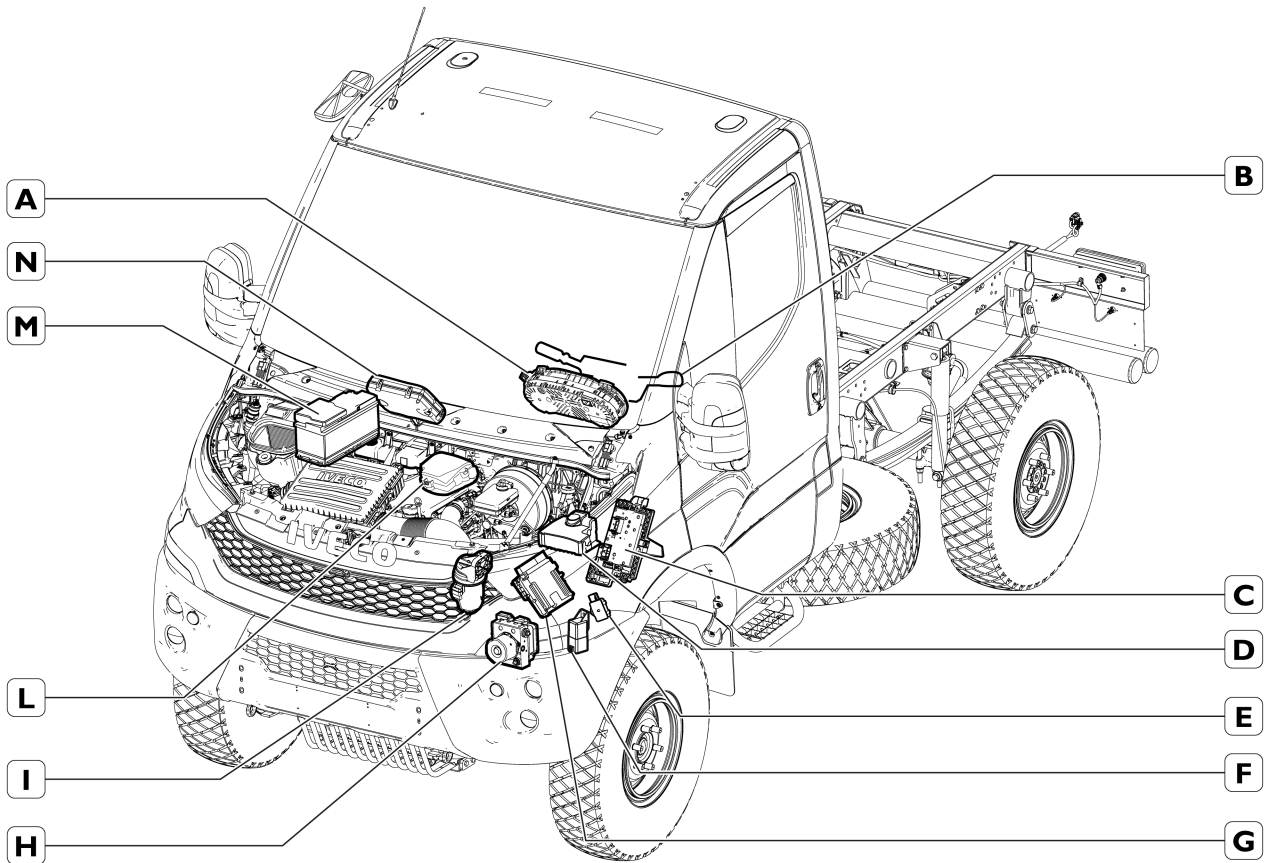

228305

Figure I

- | | |
|---|---|
| <ul style="list-style-type: none"> A. Instrument panel B. Steering wheel column and ignition switch C. Body Computer D. CBA2 control unit in the engine compartment E. Oil control unit F. Glow-plugs preheating control unit | <ul style="list-style-type: none"> G. Engine Management control unit H. ABS/ESP control unit I. Green filter L. SCM connection panel (engine) M. CBA1 control unit on battery N. Expansion Module |
|---|---|

5.2 BODYBUILDER CONNECTORS

Note Given the multiplicity of vehicular variants and of associated wiring, the present chapter only provides information concerning the basic version of the electrical system; please contact the IVECO Assistance Service should you require more specific information.

The vehicle's electrical system contains specific connectors for connecting the bodybuilder installations; access to these allows the system's functional integrity and validity of the warranty to be preserved.

The standard connectors are the 61071A and 72075A, interfaced with the cab dashboard cable, which are accessible after removing the panel of the passenger side glove box (see Figure 2).



- ▶ **Any taking of signals from the vehicles to the outfitting must be performed using suitable diodes, relays and bridles. Direct connection to connectors 61071A and 72075A is strictly forbidden, otherwise the warranty shall become invalid.**

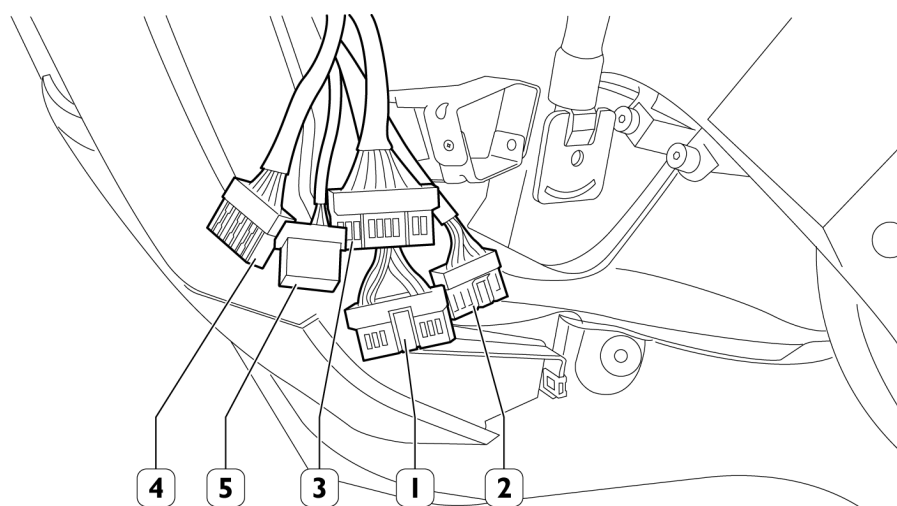

230823

Figure 2

- | | |
|---------------------------------|------------------------|
| 1. Bodybuilder Connector 61071A | 3. Connector EM 61071B |
| 2. Bodybuilder Connector 72075A | 4. Connector EM 72075B |
| | 5. Connector EM 72071 |

In the event in which the vehicle is ready for the optional installation of the Expansion Module, the electrical system in the cab is also equipped with connectors 61071B, 72071, 72075B, to which another connector ST13 is added inside the engine compartment, on the left side (see Figure 3).

The description of the function of these connectors is contained in the specific manual EM 603.95.826 (currently being updated at the time of publication of the present document).

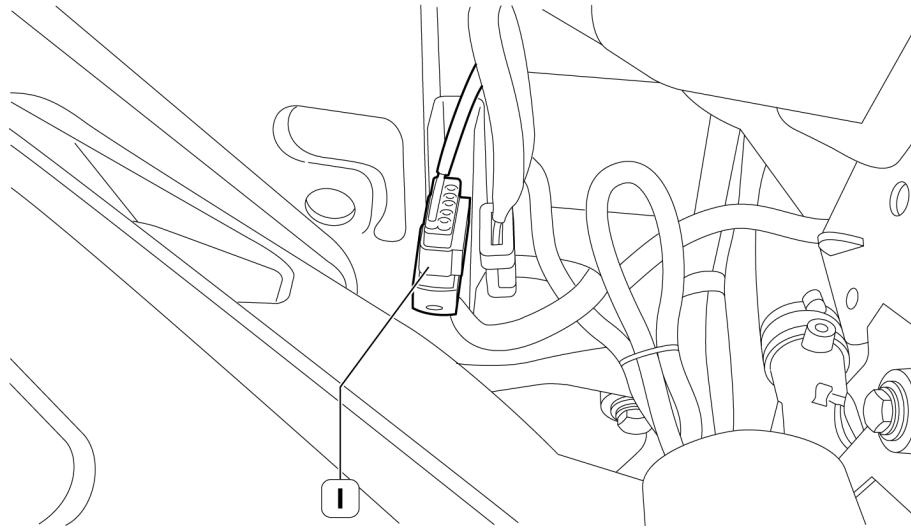

230828 **Figure 3**

1. Connector ST13

Connector 61071A, blue, 20-pin

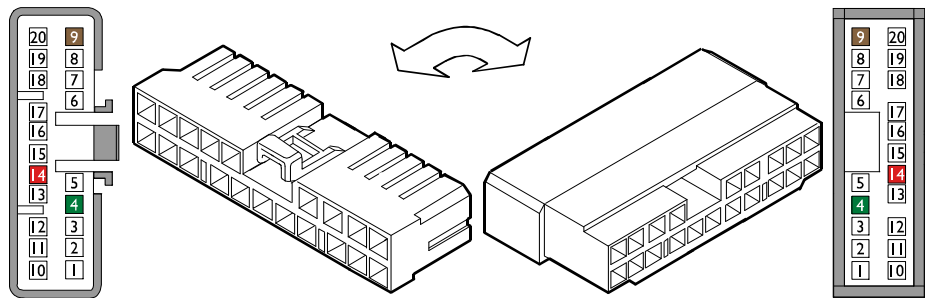

101564 **Figure 4**

A. Existing part on vehicle (male)

B. Counterpart to be coupled (female)

Table 5.1

Code	Description
500314817 EZ	20-way male door seal
500314820 EZ	Male contact for 0.35 to 0.5 mm ² cable
500314825 EZ	Male contact for 0.75 to 1.5 mm ² cable
I/05907/44 EZ	Male contact for 2.5 mm ² cable

Table 5.2 - Basic functions of the 20-pin connector 61071A

Pin	Description	Cable code	Signal	Connected to	Remarks
1	Engine start-up	8888	Input Max 20 mA	BCM A/19	The engine starts only when the key is turned in the ignition block (K15 ON) ⁽¹⁾ +12 V = engine start-up Open wire = no action
2	Engine shut down	9903	Input Max 10 mA	BCM F/22	The engine only switches off with vehicle speed < 4 km/h ⁽²⁾ + 12 V = engine stop Open wire = no action
3	Service braking	1176	Output Max 500 mA (with decoupling diode)	BCM D/57	+12 V = brake activated no signal = brake not activated
4	Stationary vehicle	0000	Output Max 500 mA (with decoupling diode)	BCM H/32	Ground = stationary vehicle no signal = vehicle is not stationary
5	Parking braking	6662	Output Max 500 mA (with decoupling diode)	BCM F/44	Ground = parking brake engaged ⁽³⁾ no signal = parking brake not engaged
6	Battery positive	7772	max 15 A	BCM E/19	Positive protected by fuse on Body Computer - F33
7	Ignition of side lights	3320	Output Max 500 mA	Relay managed by BCM	A positive signal is obtained when the side lights are on ⁽⁴⁾ +12 V = side lights active no signal = side lights inactive
8	Reserved				⁽⁵⁾
9	Clutch actuation	9273	Output Max 500 mA (with decoupling diode)	EDC K/44	+12 V = clutch not depressed no signal = clutch depressed
10	Engaging reverse	2268	Output Max 100 mA (with decoupling diode)	BCM C/17	+12 V = reverse gear engaged no signal = reverse gear not engaged
11	Positive with key	8879	Output max 5 A	BCM G/12	Positive with key protected by fuse on Body Computer - F49
12	Cruise Control Command	8156	Input (...)	BCM H/56	Cruise Control interface ⁽⁶⁾
13	Reference ground for Cruise Control command transfer box	0000	Input (...)	BCM H/45	Ground for Cruise Control interface
14	Reserved				
15	Reserved				
16	Reserved				
17	Ground	0000	Output max 15 A		Ground connection
18	Reserved				
19	Reserved				
20	Reserved				

⁽¹⁾ **The vehicle does not supply any safety check. The vehicle does not prevent engine start-up with gear engaged, nor monitors the release of the clutch pedal. The bodybuilder must adopt preventative measures to avoid any unintentional movements of the vehicle.**

The engine start-up control must be permanently active until the engine starts running.

The engine only functions with the key turned in the ignition block (K15 ON).

Activating the remote signal K15 from pin 5 of connector 72075A and then inserting the key in the ignition block (K15 ON) prevents engine start-up and an Immobilizer Error is signalled. In this case it is necessary to remove both the remote signals K15 and K15 ON.

When the procedure has been performed successfully it remains valid for the entire K15 ON cycle and this allows the bodybuilder to repeatedly stop and restart the engine until K15 stays active.

The starter motor is only activated when the engine is NOT running.

⁽²⁾ Stopping the engine is only permitted when the vehicle is stationary or at a speed of < 4 km/h.

The engine stop control must be permanently active until the engine stops.

⁽³⁾ **If the “parking brake engaged” signal indicates "ground", it means the parking brake has not been fully released. Therefore a residual braking torque on the rear axle cannot be excluded. IVECO does not recommend use of the signal as an indication of a stationary vehicle.**

Obligatory insertion of a 10 kOhm pull-up resistor between 61071A / pin 11 (signal K15) and 61071A / pin 05 as outlined in Figure 5.

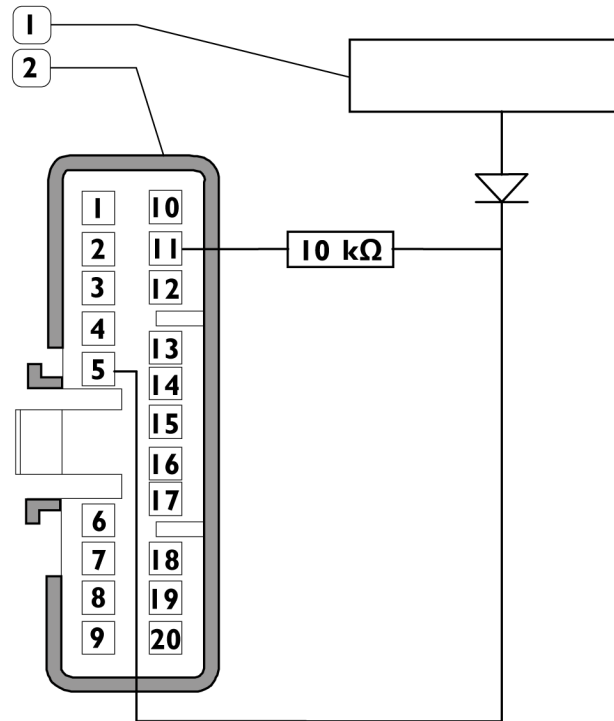

1. Outfitting

2. Connector 61071A

⁽⁴⁾ The output signal of the side markers may also be extracted from the chassis connector ST38. If necessary, consult Chapter 5.4 – Paragraph "Arrangement of side position lights (Side Marker Lamps)".

(5) On the 20-way connector 61071A the D+ signal is not available.

IVECO therefore recommends use of a relay which is able to “read” the engine speed from terminal 10 of the 12-way connector 72075A (see example in Figure 6).

This relay must be set so that, with an engine speed of >400 revs/min, a 12 V output is activated which can be used as the D+ signal.

The speed threshold for which the signal must be present is adjustable from 400 to 2000 revs/min and can also be used for other applications in which an engine speed signal is required.

If the RPM output of connector 72075A / pin 10 does not supply a signal, then the ECM programming must be updated; for this purpose, contact the IVECO Assistance Service.

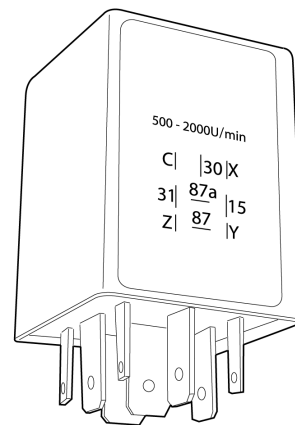

230049

Figure 6

Connection:

- X: not used
- Y: Signal input connector 72075A / pin 10
- Z: not used
- C: not used
- 15: not used
- 30: positive shared connector 61071A / pin 11
- 31: negative connector 61071A / pin 17
- 87: normally open (closing) to be used as “D+ signal”
- 87a: normally closed (opening)
- Rated voltage: 9 ÷ 15 V
- Maximum switching current: 10 A
- Operating current: 10 ÷ 100 mA
- Protection: IP52

(6) Only supported with Cruise Control option.

The resistors must be connected between pin 12 and pin 13. Different functions may be activated depending on the resistor value:

R = 2490 Ohm:	CC stays active, just like the PTO modes (important for vehicles without Cruise Control)
R = 649 Ohm SET+:	the speed increases by +50 revs/min pulse (only when the vehicle is stationary) or adjustment of the CC speed (only at V > 30 km/h)
R = 261 Ohm SET-:	the speed decreases by -50 revs/min pulse (only when the vehicle is stationary) or adjustment of the CC speed (only at V > 30 km/h)
R = 133 Ohm RES:	activation of ISC MEMO speed or resumption of the memorized CC speed

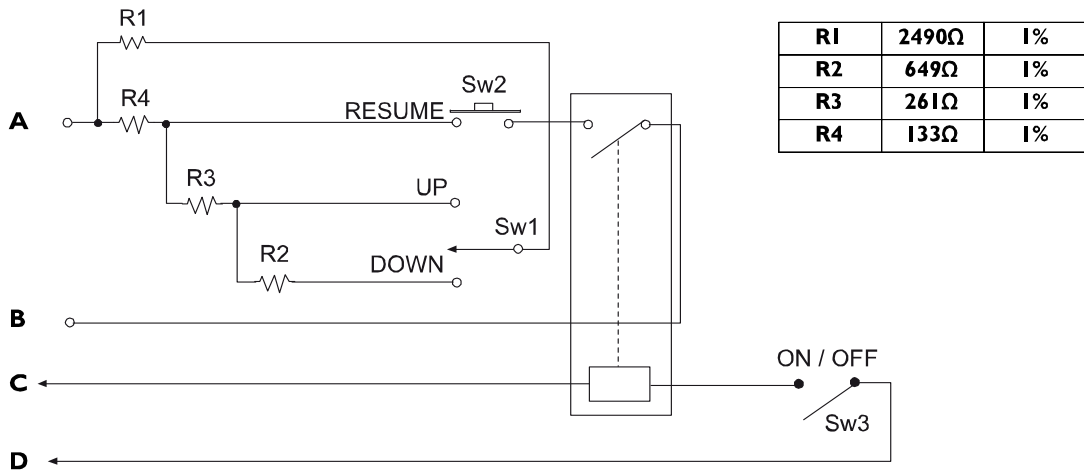

208225 **Figure 7**

- A. Pin 12 20-pin body builders connector
- B. Pin 13 20-pin body builders connector (ground)
- C. Pin 4 20-pin body builders connector (ground if V=0)
- D. Pin 11 20-pin body builders connector(+15)

For this purpose IVECO recommends use of a relay which enables utilization of the same functions available on the steering wheel lever.

The Cruise Control option must be configured on both the ECM and BCM systems.

Please note that the driver must position the Cruise Control switch on the steering wheel lever to OFF, otherwise the external controls will be ignored.

Function	Short-cut necessary	
CC Resume	Pin 2	Pin 6
CC Set-	Pin 2	Pin 8
CC Set+	Pin 2	Pin 5
CC ON	Pin 2	Pin 4

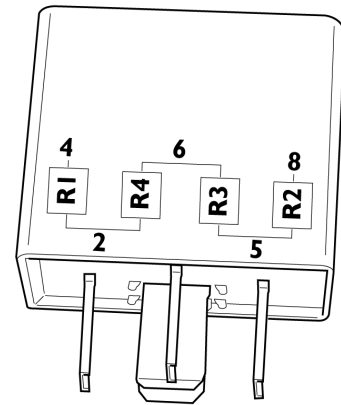

230050 **Figure 8**

Connector 72075A, black, 12-pin

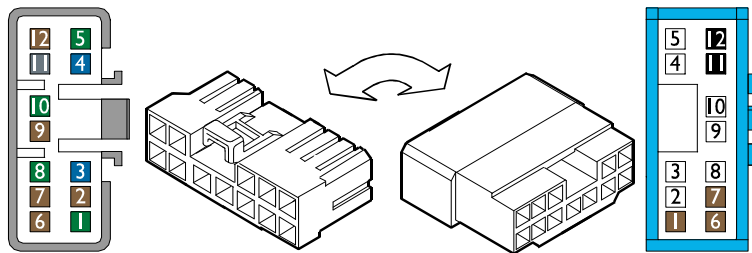

101554

Figure 9

Existing part on vehicle (male)

Counterpart to be coupled (female)

Table 5.3

Code	Description
500314814 EZ	12 way male connector
500314820 EZ	Male contact for 0.35 to 0.5 mm ² cable
500314825 EZ	Male contact for 0.75 to 1.5 mm ² cable
1/05907/44 EZ	Male contact for 2.5 mm ² cable

Table 5.4 - Basic functions of the 12-pin connector 72075A

Pin	Description	Cable code	Signal	Connected to	Remarks
1	2nd Speed limiter	0000	Input Max 10 mA	BCM H/41	Activation of 2nd speed limiter (30 km/h by default) ⁽¹⁾ Minimum value 10 km/h, which may be set by the Assistance Service Ground = 2nd speed limiter activated Open wire = no action
2	Programmable speed limiter;	9968	Input Max 10 mA	EDC K/22	Activation of programmable speed limiter Ground = programmable speed limiter activated Open wire = no action
3	Ground for Multiple State Switch	0000	(...)	BCM H/38	Ground for EDC ⁽²⁾ Multiple State Switch pin 8
4	Speed signal (B7)	5517		BCM D/56	Obligatory insertion of a 5k pull-up resistor ⁽³⁾ Use signal K15 of 61071A/pin 11 Pulse signal, see B7 tachograph signal description
5	K15 Remote	8879	Input Max 500 mA	BCM G/02	By providing a positive, the first turn of the key is simulated (key set to ON). Only the main loads are powered but it is not possible to start the vehicle from outside since the vehicle key recognition is missing. ⁽⁴⁾ +12 V = activation of K15 Remote Open wire = no action
6	Signal of PTO I in operation	6993		EM X3/08	PTO I feedback Ground = PTO I engaged Open circuit = PTO I not engaged

Pin	Description	Cable code	Signal	Connected to	Remarks
7	Horn	0000	Output Max 150 mA	BCM B/28 (t.b.d.) BCM D/51 (t.b.d.)	Remote activation of horn Ground = horn active Open wire = no action
8	Multiple switch	0000	Output (...)	BCM H/36	ISC input (Idle Speed Control) mode 1/2/3 ⁽²⁾ Note: the ISC mode must be reactivated after every engine start-up.
9	Reserved				
10	Engine speed (rpm)	5587	Output (...)	EDC K/70	Engine speed signal ⁽⁵⁾ 4 pulses/rev.
11	Not connected				
12	Not connected				

⁽¹⁾ Should you wish to change the value of the 2nd speed limiter, using the tool available at the IVECO Assistance Service, please note that:

- The accuracy of the speed limiter is reduced at low vehicle speeds.
- The accuracy of the speed limiter is reduced at low engine speeds: interference with the engine idle speed regulator is possible, particularly below 1000 rpm.
- The speed limiter must only be used in 1st gear or in reverse gear.
- The speed limiter may be adjusted in steps of 1 km/h by the IVECO Assistance Service.
- The bodybuilder must check the functionality of the speed limiter for each application and is also responsible for preparing the relative specific instructions.

⁽²⁾ The signals to the Multiple State Switch may also be simultaneous to requests coming from the Expansion Module through CAN open (object 0x2001, sub 0x0C) or through activation of "PTO1/PTO2/PTO3 Memo Speed". The highest value prevails in the event of contemporaneity.

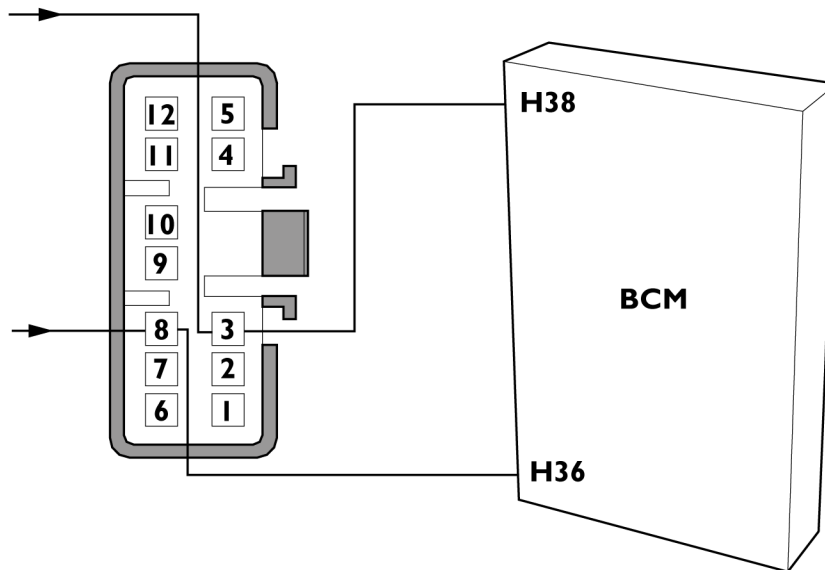

230827

Figure 10

For this purpose IVECO recommends use of a relay (not identical to that for the Cruise Control interface) which enables utilization of the same functions available on the steering wheel lever.

The Cruise Control option must be configured on both the ECM and BCM systems.

Please note that the driver must position the cruise control switch on the steering wheel lever to OFF, otherwise the external controls will be ignored.

Function	Short-cut necessary	
ISC Mode 1	Pin 2	Pin 6
ISC Mode 2	Pin 5	Pin 6
ISC Mode 3	Pin 8	Pin 6

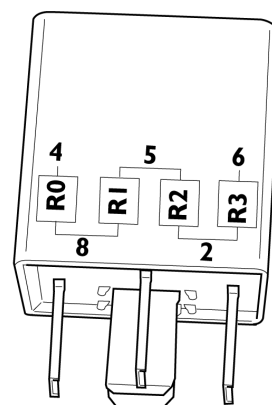

230826

Figure 11

(3) Obligatory insertion of a 5 k Ω pull-up resistor in addition to a diode as outlined in Figure 12.

The pull-up resistor and the diode must be fitted by the Bodybuilder.

The resistor must be inserted between 72075A / Pin 4 and 61071A / Pin 11.

Without the pull-up resistor no B7 signal is available.

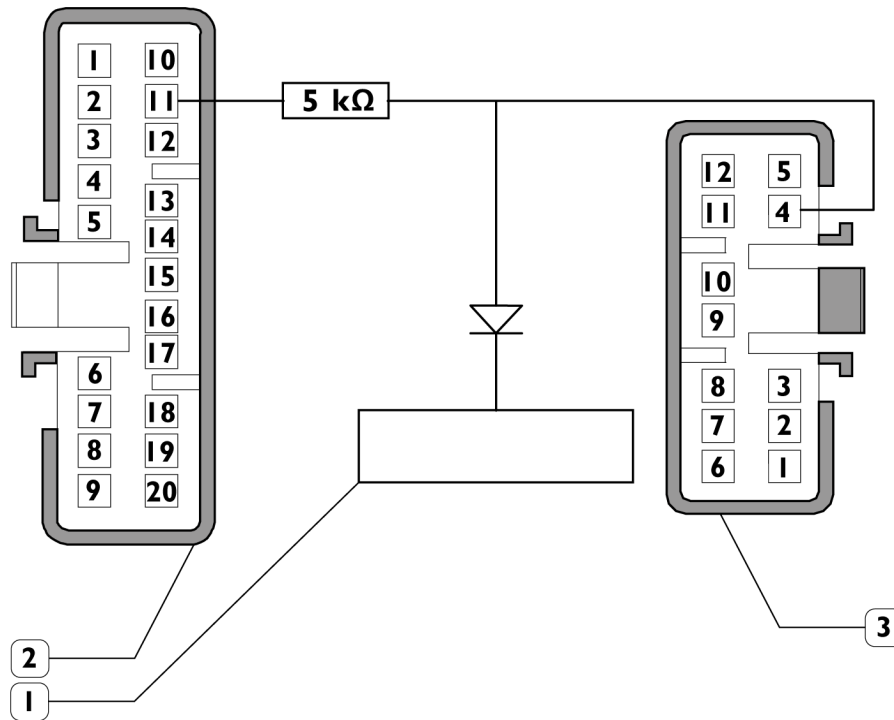

230825 **Figure 12**

- 1. Outfitting
- 2. Connector 61071A
- 3. Connector 72075A

The B7 output supplies the signal relating to the speed according to [ISO 16844-2].

Table 5.5 - Tachimetric signal characteristics

Function	Parameter	min	max	Unit of measurement	Remarks
Tachograph output B7	Voltage U_{low}		1.5	V	I = 1 mA
	Voltage U_{high}	5.5		V	I = 1 mA
	Frequency (1/T)		1.6	kHz	Square wave
	Pulse duration (t)	0.64	4	ms	

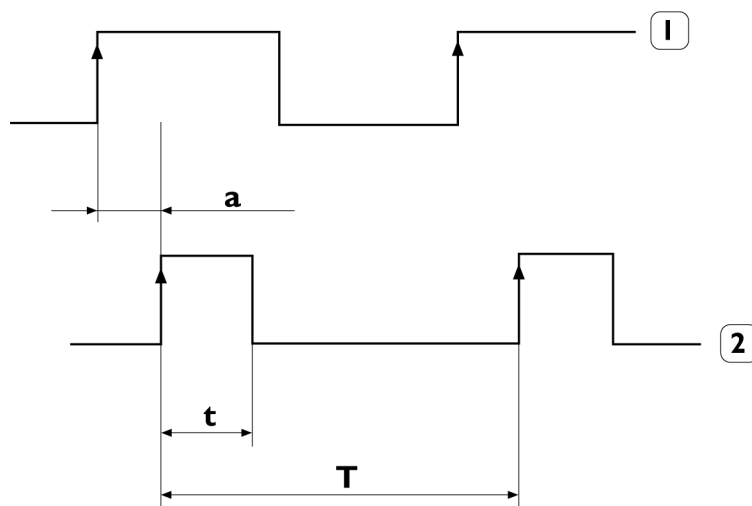

230830

Figure 13

1. Speed signal (terminal B3) of the movement sensor fitted on the reduction unit

2. Temporal diagram and form of the pulse speed signal (terminal B7) from tachograph
 a. Pulse delay: max $40 \mu\text{s} \pm 10 \mu\text{s}$ jitter

(4) WARNING:

If the K15 Remote control was activated and the operator removed the ignition key with the engine running, the engine would not stop and it would be possible to move the vehicle with the steering locked. Therefore:

- **The K15 Remote control must not be activated with the engine running.**
- **Similarly, to avoid unexpected movements of the vehicle with gear engaged, the engine must not be running when the K15 Remote control is activated.**

If, in spite of such requirements, engine operation must still be possible, IVECO recommends using the RunLock function offered by the Expansion Module (if present): please consult the specific manual EM 603.95.826 (currently being updated at the time of publication of the present document).

(5) Rpm signal

The rpm signal is a square wave.

The characteristics of the rpm signal are:

- 4 pulses for each revolution of the crankshaft;
- frequency field $0 \div 400 \text{ Hz}$ (corresponding to $0 \div 6000 \text{ revs/min}$);
- duty-cycle fixed at 50%.

Table 5.6 - Engine speed signal characteristics

Characteristics	Condition	Minimum	Maximum	Unit of measurement
C_EMI		3.76	5.64	nF
C_IO		3.76	6.14	nF
I_Out			2.2	A
I_Out_SC			4	A
I_Leak_Off			20	μA
I_Out_Diag			980	μA
V_OC		3.23	3.77	V
V_THR		4.7	5.4	V
V_Out_Low			1.76	V
R_ON			800	mΩ
E_Clamp			4	mJ
V_Out_Clamp			60	V
R_Load_Diag			4.69	kΩ

Legend:

- C_EMI: EMI capacity at the connector terminals
- C_IO: capacity between input and output (in the event of output stage: C_IO is valid if the output stage is turned off)
- I_Out: output current
- I_Out_SC: output current
- I_Leak_Off: loss of current if the ECU is no longer powered
- I_Out_Diag: loss of current with ECU powered, but PS no longer powered. This parameter defines the ability of the hardware to provide a diagnostic current. The actual existence of the diagnostic current depends on the software configuration
- V_OC: voltage between CON_PIN and ground with open circuit
- V_THR: open load threshold voltage
- V_Out: output voltage
- V_Out_High: output voltage, HIGH level
- V_Out_Low: output voltage, LOW level
- R_ON: output resistor ON
- E_Clamp: energy at the output terminals
- V_Out_Clamp: voltage at the output terminals
- R_Load-Diag: Maximum diagnosable load resistance
- t_Fall: signal fall time from 90% to 10%

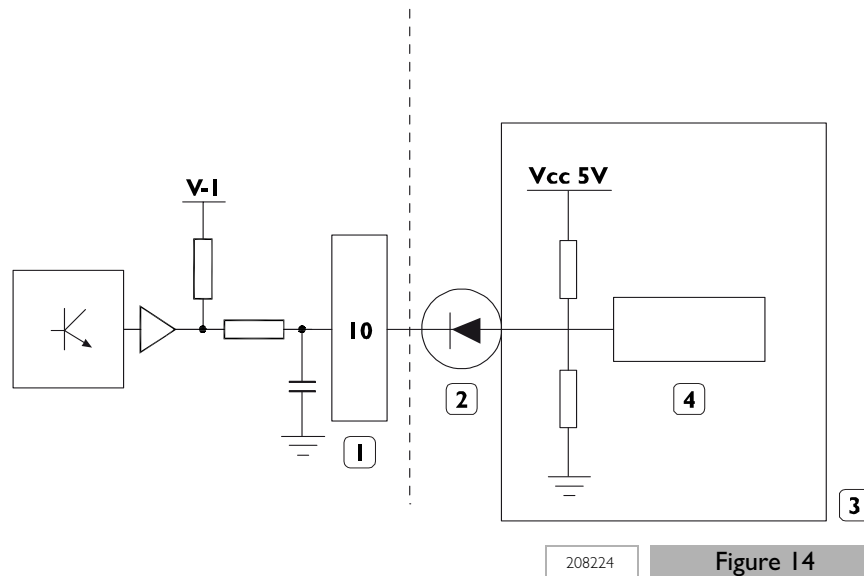

208224

Figure 14

1. Body builders connector
2. Separation diode **REQUIRED**

3. Interface responsibility of the designer of the processor
4. Signal processor

The bodybuilder must install a special separation diode so as not to lower the V_{ON} voltage.

The designer of the signal processor must ensure an input interface equal to that represented with a max. voltage V_{CC} of 5 V and "pull-up / pull-down" so as not to lower the voltage V_{ON} and to raise the response time set by the vehicle interface.

5.3 ELECTRONIC CONTROL UNITS

Precautions to be used with electronic control units installed

In order to avoid operations that could permanently damage or degrade the functioning of the vehicle ECUs, it is advisable to:

- remember that connection and disconnection from battery terminals may generate voltages that adversely affect vehicle electronic systems and control units;
- do not disconnect and/or connect connectors from/to the control units with engine running or control units powered;
- detach the electronic control units where particular processing operations involve temperatures above 80°C;
- absolutely never employ a rapid battery charger for emergency start-up because it could damage the electronic systems, particularly the control units that manage the ignition and power supply functions;
- do not supply current to components served by electronic modules with jumper cables
- connect the control units equipped with metal casing to the ground of the system using a screw or bolt unless otherwise specified.

In case of any work on the chassis requiring arc welding:

- disconnect CBA I from the battery positive terminal and do not connect it to the chassis ground;
- disconnect the control unit connector;
- disconnect the control unit from the chassis (in case of welding near the control unit itself);
- perform welding with continuous current;
- ground the welding machine as close as possible to the welding point;
- do not place the battery cables parallel to the vehicle's electric cables.



- ▶ **Use only fuses with the features prescribed for the specific function. NEVER USE FUSES WITH A CAPACITY HIGHER THAN THE PRESCRIBED. Replace using only keys and disconnected users.**

Restore the original conditions of the wiring (paths, protections, strips, **completely** preventing the cable from coming into contact with the surface of the metal structure that can affect its integrity), if operations have been carried out on the system.

Warning

The vehicles are equipped with sophisticated electrical/electronic systems that monitor their operation (e.g. ABS, EDC, etc.).

Therefore, before installing additional heaters, power take-offs, speed limiters, anti-theft devices, mobile phones or refrigerator compressors for systems that can interact with these electronic systems, it is advisable to verify the feasibility of the application with IVECO.

In addition, it is necessary that adequate diagnostic checks are carried out to verify the proper construction of the system.

For more detailed information on the vehicle's electrical system, refer to the specific Repair Manuals.



- ▶ **Electrical work (e.g. removing cables, adding circuits, replacing equipment or fuses, etc.), performed in a manner inconsistent with the IVECO instructions or by unqualified personnel, can cause serious damage to electronic control units and compromise driving safety.**



- ▶ **Any electrical work that is carried out in non-compliance with regulations may cause substantial damage (e.g. short circuits with the possibility of fire and destruction of the vehicle) and authorises IVECO to annul the warranty.**

Note For any exception to mounting instructions, IVECO's written authorisation is necessary.

Lack of observance of above described prescriptions involves guarantee lapse.

Disconnecting electronic control units



- ▶ **Interventions which do not comply with the instructions specified by IVECO or which are performed by unqualified personnel may cause severe damage to on-board systems, affect driving safety, reliability and vehicle functioning and cause considerable damage which is not covered by the warranty.**

The following instructions must be strictly observed before disconnecting an electronic control unit:

- turn the ignition key to OFF and remove it;
- switch off the additional heaters and wait for the end of the cooling down cycle (the warning light of the corresponding key will go out);
- switch on the reading spotlights centrally positioned on the cross member;
- isolate the battery by disconnecting the power cables: first the negative pole followed by the positive pole; the aforesaid spotlights are now off;
- disconnect the control unit.

Repositioning electronic control units

IVECO recommends avoiding modifications which entail the repositioning of the electronic control units. However, if repositioning is unavoidable, please follow the instructions below:

- the electronic control units must be positioned on the chassis or in the cab and secured with a fastening similar to the original one (i.e. suitable bracket); The device must not be rotated in relation to the chassis so as to avoid potential malfunctions (eg. infiltration of water). Therefore the original positioning must also be maintained;
- the electronic control units must not be fitted on the counter chassis;
- the covering must always be reinstalled;
- the control units must not be subjected to impact from road debris or stones coming from the vehicle's wheels when in motion.

5.4 ELECTRICAL SYSTEM: CURRENT INTERVENTIONS AND DRAWS

General information

Vehicles are set to function normally with a 12 V electrical system.

The chassis represents the grounding (it acts as a current return conductor between the components located on it and the battery power source/alternator) and it is connected to the negative pole of the battery and components, if an isolated return is not provided for this.

When installing additional equipment or additional circuits, the following indications must be taken into account and, depending on the complexity of the operation, there must be proper documentation (e.g. wiring diagram) to match that of the vehicle.

The use of cables and connections with colours/codes identical to those used on the original vehicle makes installation correct and facilitates any repair work.

For effective and proper use of the electrical system, specific connection points for additional equipment have been prepared. This was necessary to exclude any type of alteration of the basic design, so as to ensure its functional integrity and therefore maintain the vehicle guarantee.

Note For more detailed information on the vehicle's electrical system, please consult the NEW DAILY 4x4 Repair Manual, printout no. 603.95.979.

This manual is available at the Service Network and can also be obtained from Sales Agencies.

Precautions for work on the system



- ▶ **Interventions on the electrical system (e.g. removal of cables, addition of circuits, replacement of equipment or fuses etc.) carried out in a manner which is not compliant with IVECO's instructions or carried out by non qualified personnel, can cause severe damage to on-board systems (control units, wiring, sensors etc.), affect driving safety and good operation of the vehicle and cause serious damage to the vehicle (e.g. short circuits with the possibility of fire risk or destruction) which is not covered by warranty.**

Before removing any electrical/electronic equipment, disconnect the ground cable from the battery negative pole and then the positive cable.

To prevent damage to the vehicle's electrical system, follow the instructions of the cable manufacturer.

- The cables must have suitable sectioning for the type of load and the position of the load in the vehicle.
- The power cables (+ direct) must be:
 - individually intubated in conduits (of suitable diameter) and not together with other different cables for signal and negative;

- placed at least 100 mm (reference value = 150 mm) from high heat sources (turbine, engine, exhaust manifold, etc.);
- placed at least 50 mm from containers of chemical agents (batteries, etc.);
- placed at least 50 mm from moving parts.
- The path of the cables must be defined with brackets and clamps dedicated and reconciled, to avoid hanging parts and to be able to restore the same installation after repairs or interventions.
- The cables must have a suitable sectioning for the type of load and the position of the load in the vehicle.
- The passage of cables through holes and on the edges of metal sheets must be protected by cable gaskets in addition to the corrugated tube
It is not possible to specially drill the chassis to allow the cables path.
- The corrugated tubing must completely protect the entire cable and be connected (with heat shrinking or taping) to the rubber caps on the terminals.
- All the positive terminals and cable terminals must be protected by rubber caps (for hermetic in areas exposed to weathering or with possible stagnation of water).

Use fuses with the prescribed capacity for the specific function, and do not under any circumstances use higher capacity fuses.

Restore the original condition of the wiring (paths, protections, strips) making absolutely certain that the cable does not come into contact with any metal surfaces of the structure which could affect its integrity.

Precautions for work on the chassis

For work on the chassis, to protect the electrical system, its equipment and ground connections, respect the precautions shown in Chapter 2.1 - Paragraph "Special precautions (►► Page 5)" and Chapter 2.3 - Paragraph "precautions (►► Page 11)".

In cases where the application of additional devices requires it, the installation of protective diodes for inductive current spikes must be provided for.

The ground signal from the analogue sensors must be wired exclusively on the specific receiver; additional ground connections may distort the output signal from this sensor.

The cable bundles for low signal intensity electronic components must be arranged parallel to the metal plane of reference, that is adherent to the chassis/cab structure, in order to minimise parasitic capacities; space the path of the cable bundle added to the existing one as much as possible.

The added systems must be connected to the ground of the system with the utmost care (see Chapter 5.4 - Paragraph "Ground points (►► Page 22)"); the related wiring harnesses should not be coupled to the electronic circuits that already exist on the vehicle in order to avoid electromagnetic interference.

Ensure that the wiring of the electronic devices (length, type of conductor, dislocation, strips, cable shielding connection, etc..) comply with the original IVECO provision.

Carefully restore the original system after any operations.

Starting the engine

- If the engine fails to start because of the battery and not because of problems with the electrical system, do not try to start the engine by towing.
- The battery must be disconnected from the vehicle's electrical system before recharging it.
- Starting the engine with auxiliary methods must only be carried out using an external battery trolley.



► **It is strictly FORBIDDEN to use a quick battery charger for emergency start-up: due to the high voltages applied, the electronic systems and the control units could be seriously damaged. Any damage to the electronic control units is not covered by the warranty.**

- The tanks must contain sufficient fuel during the engine start-up phase, in order to avoid serious damage to the injection system.

Ground points

In general, original vehicle ground connections are not to be modified; in cases where these connections must be moved or new connections added, use the holes present on the chassis to the extent possible, taking care to:

- mechanically remove - either by filing and/or with a suitable chemical based solution - the paint on both the chassis and terminal side, thus creating a contact surface free of indentations and edges;
- paint the area between the terminal and metal surface with a suitable high conductivity paint
- connect to earth within 5 minutes after application of the paint.

As regards the signal related ground connections (e.g. sensors or low-absorption devices), do not use the standardized points. Under no circumstances use standardized points for engine ground connection and chassis ground connection.

Additional signal grounds must be positioned at different points from the power ground.

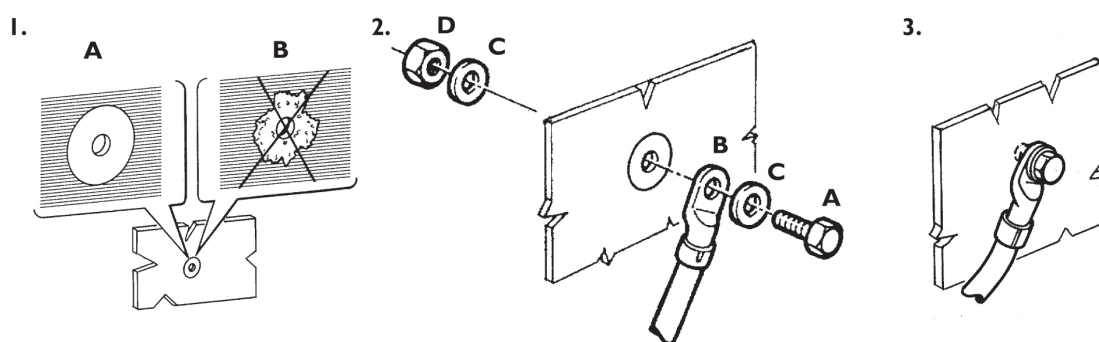

191316

Figure 15

1. Ground connections: (A) connection is correct; (B) connection is incorrect
2. Correct cable fastening to the ground point using: (A) screw, (B) cable terminal, (C) washer, (D) nut
3. Cable connected to ground

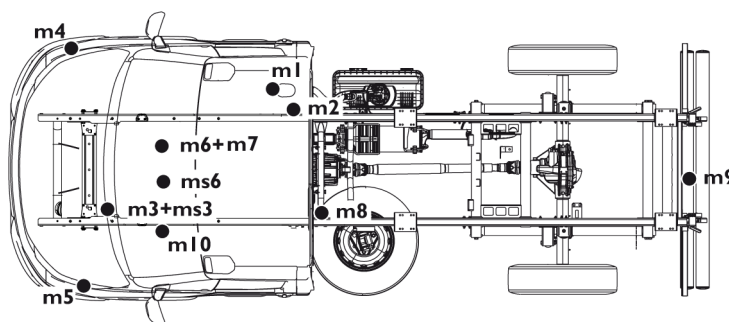

228306

Figure 16

Position of ground points on vehicle

- | | | | |
|---------|--|---------|---|
| m1. | Ground for battery/body | m5. | Ground for engine compartment behind the front left headlight |
| m2. | Ground for body/chassis | m6/ms6. | Cab interior ground, central section |
| m3/ms3. | Engine compartment ground under servobrake | m7. | Cab interior ground, central section |
| m4. | Ground for engine compartment behind the front right headlight | m8. | Ground on chassis behind the cab |
| | | m9. | Ground on left side rear cross member |
| | | m10. | Ground on chassis |

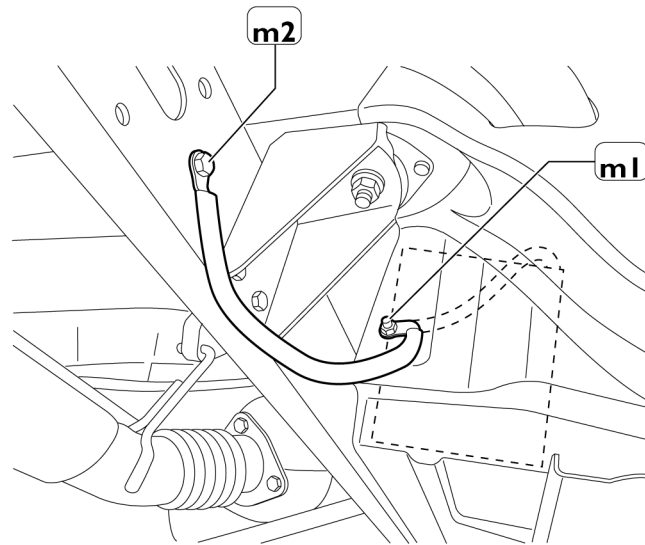

230821 **Figure 17**

m1. Ground for battery-body

m2. Ground for body-chassis

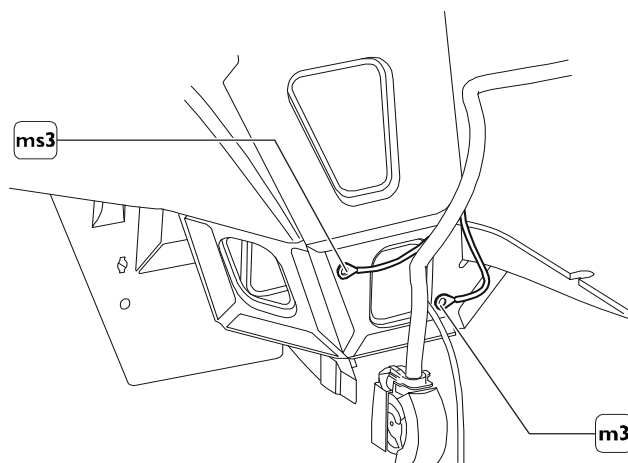

208941 **Figure 18**

m3/ms3 Engine compartment signal/power ground below servo-brake

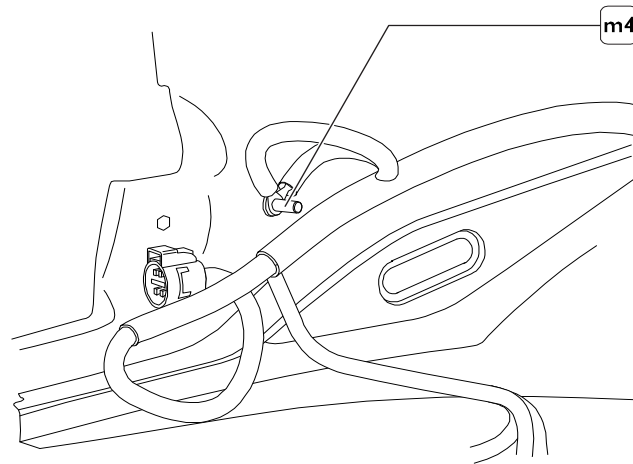

208942

Figure 19

m4. Engine compartment ground near front right headlight

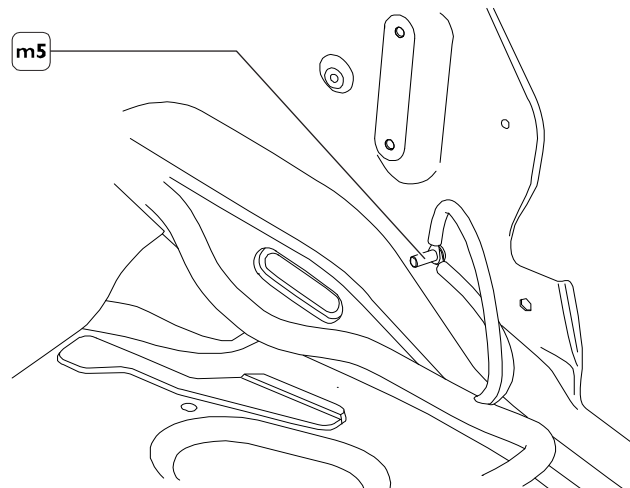

208943

Figure 20

m5. Engine compartment ground near front left headlight

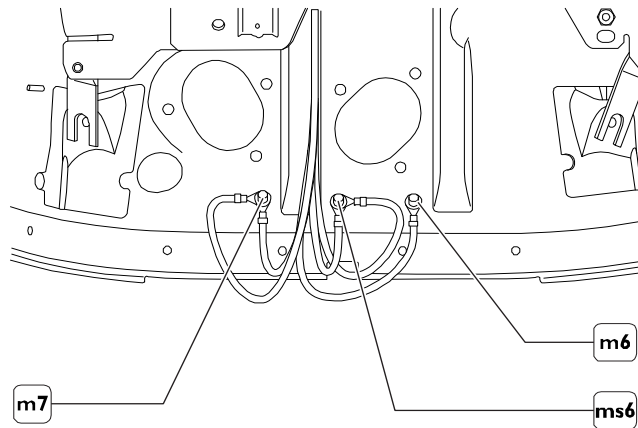

208944 **Figure 21**

m6/ms6. Signal/power ground inside cab on the central body panel below the tachograph

m7. Ground inside cab on the central body panel below the tachograph

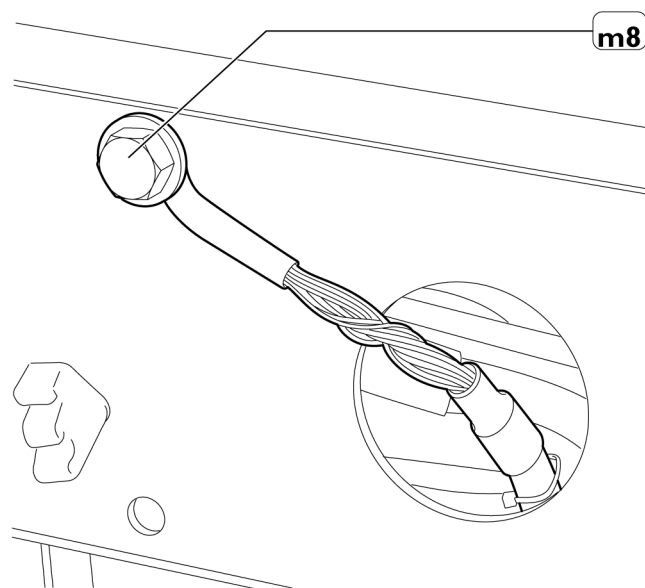

230822 **Figure 22**

m8. Ground on chassis behind the cab

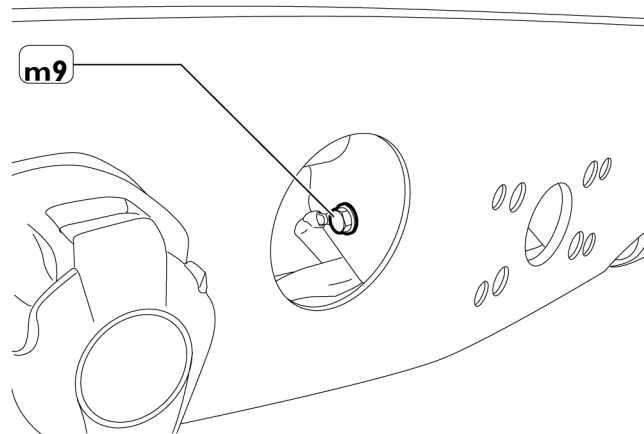

120383

Figure 23

m9. Ground on left side rear cross member

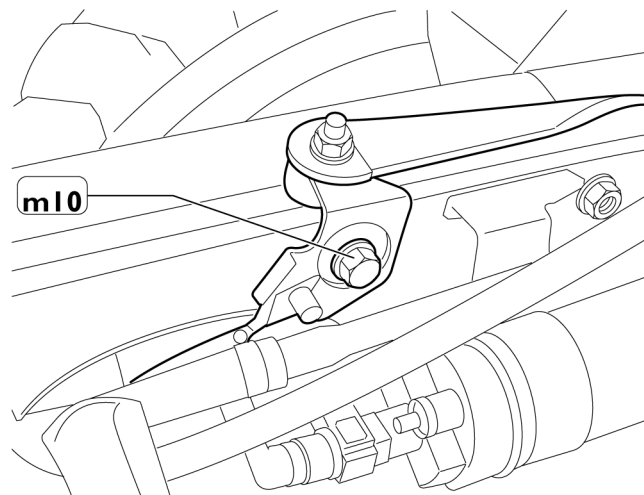

230829

Figure 24

m10. Ground on chassis

The negative leads connected to a ground point in the system must be as short as possible and must be connected to each other in a "star" formation, while tightening must be done in an orderly and adequate manner.

As far as electronic components are concerned, the following instructions should be followed:

- electronic control units must be connected to the system ground when equipped with metal housings
- the negative cables of the electronic control units are to be connected to a system ground point, connected to the negative terminal of the battery;
- the analogue grounds (sensors), while not being connected to the system ground/negative terminal of the battery, are to have good conductivity. Consequently, particular care should be given to terminal parasitic resistances: oxidation, scratches, etc
- the metal braid of the shielded circuits must be in electrical contact only at the control unit side to which the signal is to be sent
- In the presence of junction connectors the unshielded section d, near them, should be as short as possible;
- The cables must be routed in such a way as to be parallel to the reference plane, as close as possible to the chassis/body.

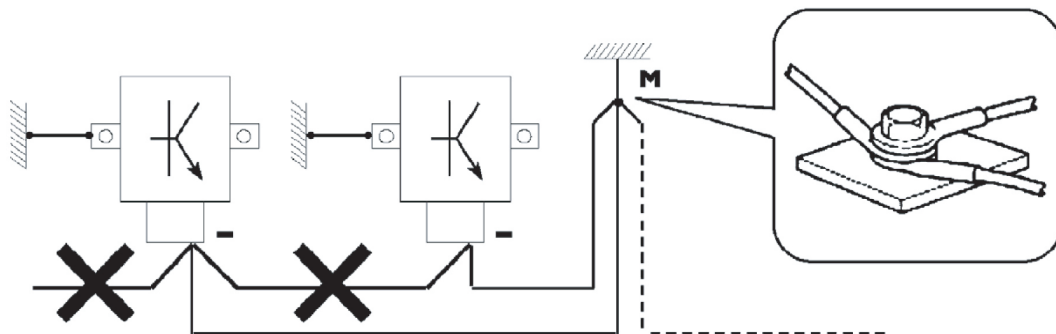

191317 **Figure 25**

"STELLA" connections of various negatives with the system ground

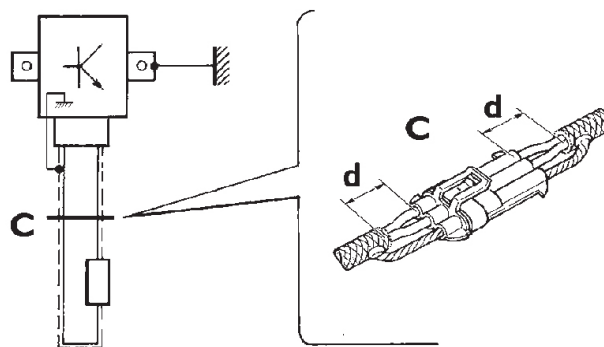

191318 **Figure 26**

Shielding by means of a metal braid of a cable leading to an electronic component

Electromagnetic comparability

It is recommended that electrical, electro-mechanical and electronic devices which comply with the following immunity requirements for electromagnetic emissions, both irradiated and conducted, are used, as shown below:

The level of electromagnetic immunity of the electronic devices equipping the vehicle at a distance of one metre from the transmitting aerial must be:

- 50 V/m immunity for devices performing secondary functions (not impacting on direct vehicle control), for frequencies varying from 20 MHz to 2 GHz
- 100 V/m immunity for devices primary secondary functions (not impacting on direct vehicle control), for frequencies varying from 20 MHz to 2 GHz.

The maximum excursion allowed for transient voltage with appliances powered at 12 V is +60 V, measured at the terminals of the artificial network (L.I.S.N.) if tested at the bench; otherwise, if tested on the vehicle, the excursion must be recorded in the most accessible location close to the disruptive device.

Note Devices powered at 12 V be immune to interferences such as negative spikes of -300 V, positive spikes of +100 V, bursts of +/- 150 V.

They must operate correctly during the phase when voltage drops to 5 V for 40 ms and to 0 V for 2 ms.

They must also resist the load dump phenomena up to 40 V.

The maximum radiated emission levels measured at the bench and the levels of conducted emissions generated by devices and also by 12 V power supplies are given in the following table:

Table 5.7 - Electromagnetic emission levels

Type of emission	Type of transducer	Type of disturbance	Type of detector	Frequency range and limits acceptable in dB μ V/m									Unit of measurement
				150-300 kHz	0.53-2 MHz	5.9-6.2 MHz	30-54 MHz	68-87 MHz mobile services only	76-108 MHz broadcast only	142-175 MHz	380-512 MHz	820-960 MHz	
radiated	Aerial at a distance of 1 metre	Broad-band	almost peak	63	54	35	35	24	24	24	31	37	dB μ V/m
radiated		Broad-band	peak	76	67	48	48	37	37	37	44	50	
radiated		Narrow band	peak	41	34	34	34	24	30	24	31	37	
conduit	LISN 50 Ω 5 μ H 0.11 μ F	Broad-band	almost peak	80	66	52	52	36	36	Not applicable			dB μ V
conduit		Broad-band	peak	93	79	65	65	49	49				
conduit		Narrow band	peak	70	50	45	40	30	36				

Use electrical/electronic equipment in compliance with the UNECE directive on electromagnetic compatibility.

Only components with certified approval and with mark "e" are allowed: the "CE" marking is not sufficient.

By way of example, the mark prescribed by the current UNECE IOR3 on electromagnetic compatibility in the automotive field is shown below:

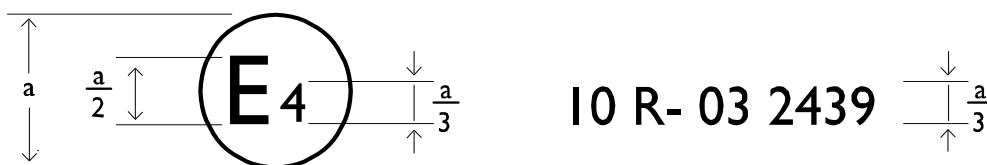

191312

Figure 27

$a \geq 6$ mm

The values in the table are only to be considered respected if the device comes from "IVECO Spare Parts" or it has been certified as per the international standards ISO, CISPR, VDE etc.

Whenever equipment is used which runs on mains power (220 V AC) for its primary or secondary source of power, it must be checked to ensure that its characteristics are in line with IEC regulations.

Reception/transmission systems

The most frequent applications include:

- amateur receiver-transmitter units for CB (City Band) and 2 m bands.
- GPS receiver and satellite navigation units.

General instructions

1. The equipment must be approved according to the law and be of a fixed nature (not portable).
The use of non approved transmitters or supplementary amplifiers could seriously impede the correct functioning of the electrical/electronic devices normally supplied, with negative effects for the safety of the vehicle and/or the driver.
2. The system already provided on the vehicle must be used to power the transmitters and they must be connected to terminal K30 of the connector ST40 (and K15 where necessary) via a supplementary fuse.
Any additional power lines must be created respecting the correct sizing of cables and protection.
3. The coaxial antenna cable must be positioned taking care to:
 - use a low loss, top quality product with the same impedance as the transmitter and the antenna (see Figure 29);
 - in order to avoid interference and malfunctioning, create a path (the shortest possible) which maintains a suitable distance (min. 50 mm) from pre-existing cabling or from other cables (radio, amplifiers and other electronic equipment), keeping the minimum distance from the metal structure of the cab and using existing holes in the sheet metal;
 - do not shorten or lengthen; avoid unnecessary tangles, tension, folds and crushing.
4. Outside the cab, the antenna must be installed on the vehicle on a metal base with a wide surface; it must also be fitted as vertically as possible with the connection cable pointing downwards and, in any case, following the manufacturer's fitting instructions and warnings (see Figure 28).
Installation at the centre of the roof is to be considered the absolute best as the ground plane is proportional in all directions.
Inside the cab, the transmitter equipment must be positioned as shown in Figure 30.
5. The quality of the antenna, the mounting position and a perfect connection to the vehicle structure (ground) are factors of fundamental importance to guarantee the best performance of the transmitter equipment.

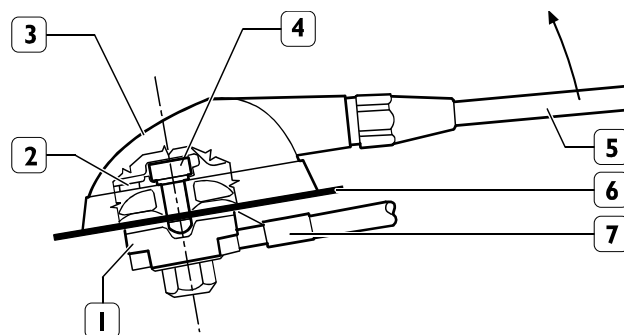

98915

Figure 28

1. Antenna support
2. Gasket
3. Fixed joint cover

4. Fastening screw M6x8.5 (tighten to a tightening torque of 2 Nm)
5. Aerial
6. Roof panel
7. Antenna extension cable

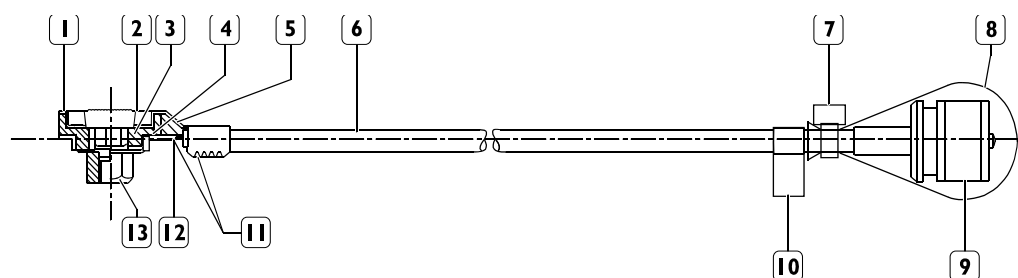

99349

Figure 29

- | | |
|--|--|
| <ol style="list-style-type: none"> 1. Antenna connector 2. Ground wire 3. Insulator 4. Signal wire 5. Condenser (100 pF) 6. Cable RG 58 (characteristic impedance = 50 Ω) 7. Clamp 8. Protection cap | <ol style="list-style-type: none"> 9. Connector (N.C. SO - 239) transreceiver side 10. Test executed sticker 11. The 100 pF condenser must be soldered on the lower pin and crimped to the ground braid 12. The lower pin must be soldered to the core conductor of the cable 13. Nut |
|--|--|

Some specific instructions are given below for each type of equipment.

Amateur equipment for CB (27 MHz) and 2 m band (144 MHz)

The transmitter part must be installed in a separate area from the vehicle's electrical components; if the transmission is impulsive it must be at a distance of least one metre away from other devices.

- The ROS value (Stationary Wave Ratio) must be as close as possible to the unit (the recommended value is 1.5), while the maximum acceptable value must never be greater than 2.
 - The ANTENNA GAIN values must be as high as possible and guarantee a sufficient level of spatial uniformity, characterised by deviations in relation to the average value to the order of 1.5 dB in the typical CB band (26.965-27.405 MHz).
 - The IRRADIATED FIELD in cab value must be as low as possible, and however < 1V/m.
- In any case, limits set by the applicable European legislation must never be exceeded.

To determine whether the system is functioning well and to check that the antenna is calibrated, it is suggested that the following information is taken into account:

1. if the ROS (Stationary Wave Ratio) is higher on the lower channels than on the higher ones, the antenna should be lengthened
2. if the ROS (Stationary Wave Ratio) is higher on the higher channels than on the lower ones, the antenna should be shortened

After having calibrated the antenna, it is advisable to re-check the ROS (Stationary Wave Ratio) value on all the channels.

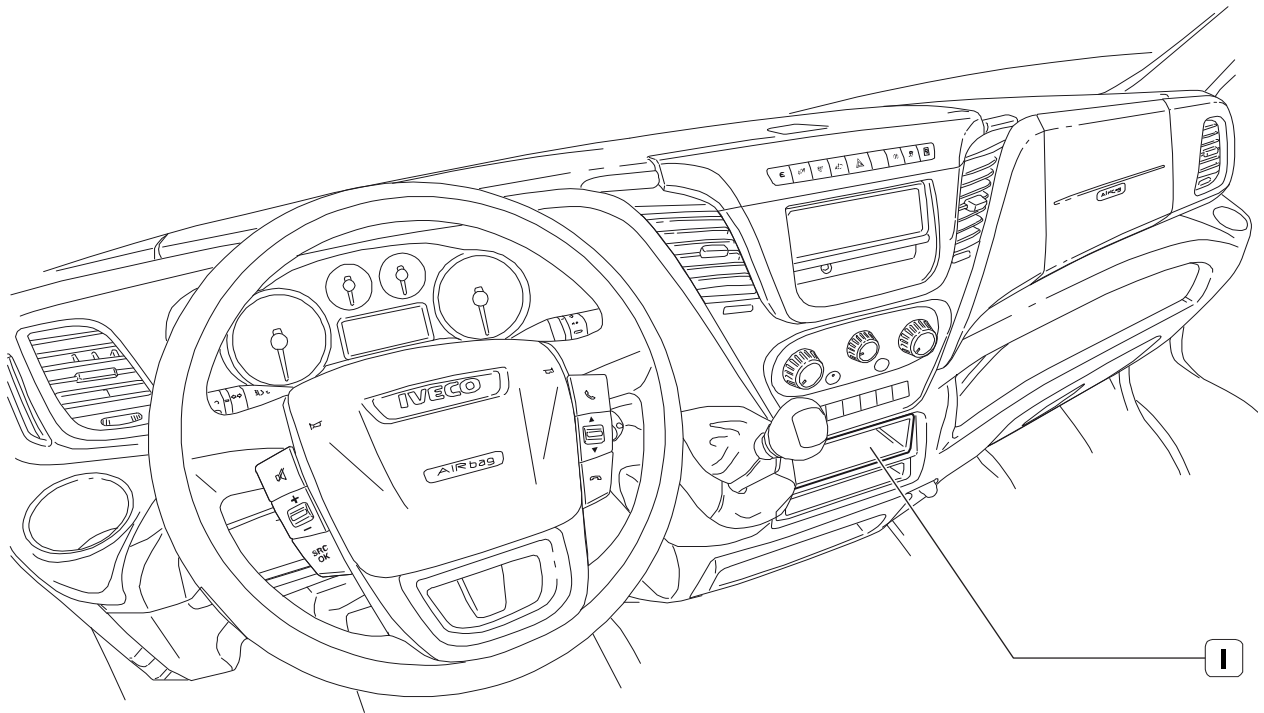

208937

Figure 30

I. Location of the CB receiver-transmitter equipment

Bluetooth setup

The Bluetooth setup consists of:

- specific control unit, positioned above the radio and hidden by a plastic cover,
- buttons on the steering wheel;
- ceiling fixture with microphone;
- USB socket;
- wiring.

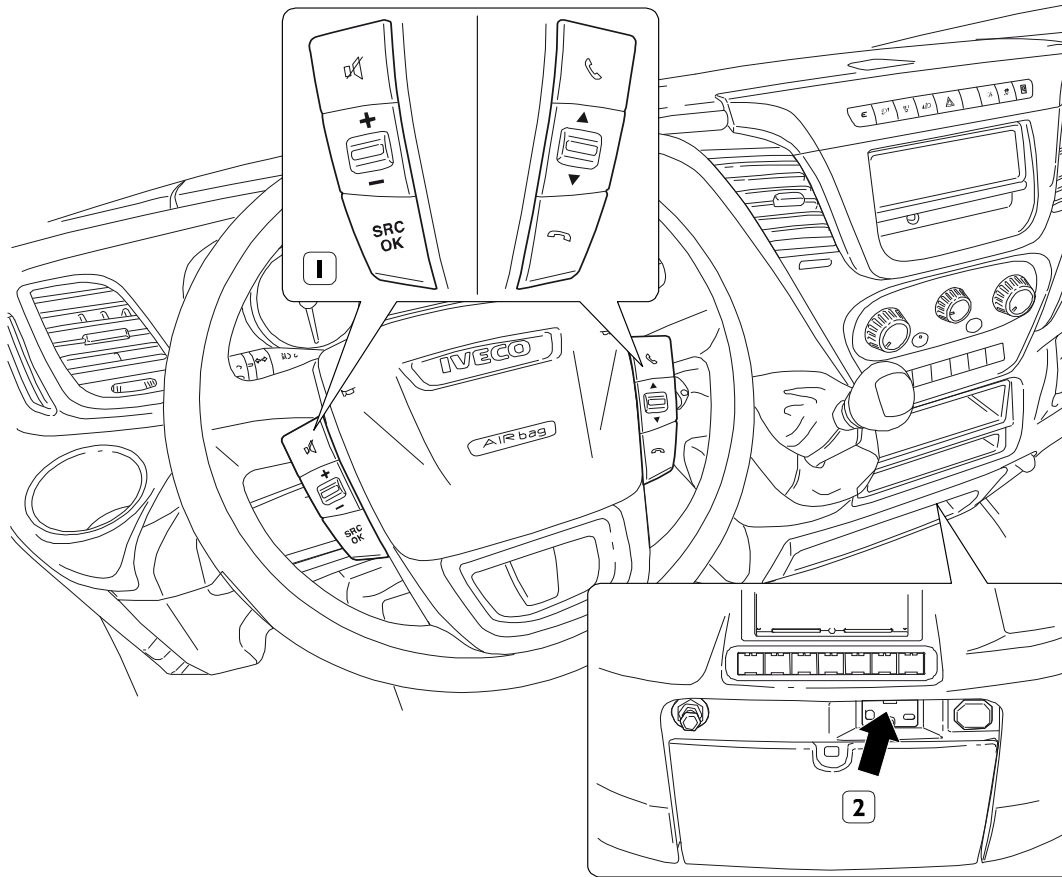

208938

Figure 31

1. Buttons on the steering wheel

2. USB socket

For cowl version vehicles the ceiling fixture with microphone is provided in the box of accompanying material.

If installation in the cab requires it, the microphone can be removed and recovered; its position, however, must be made at a point as far away as possible from sources of noise and with respect to the reception area described in the following image.

5.4 ELECTRICAL SYSTEM: CURRENT INTERVENTIONS AND DRAWS

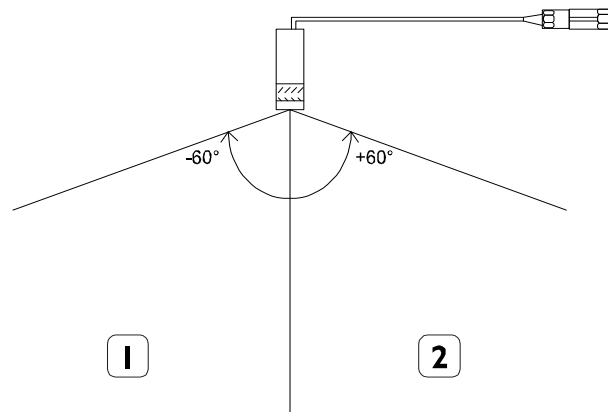

208949 **Figure 32**

1. Driver's side

2. Passenger side

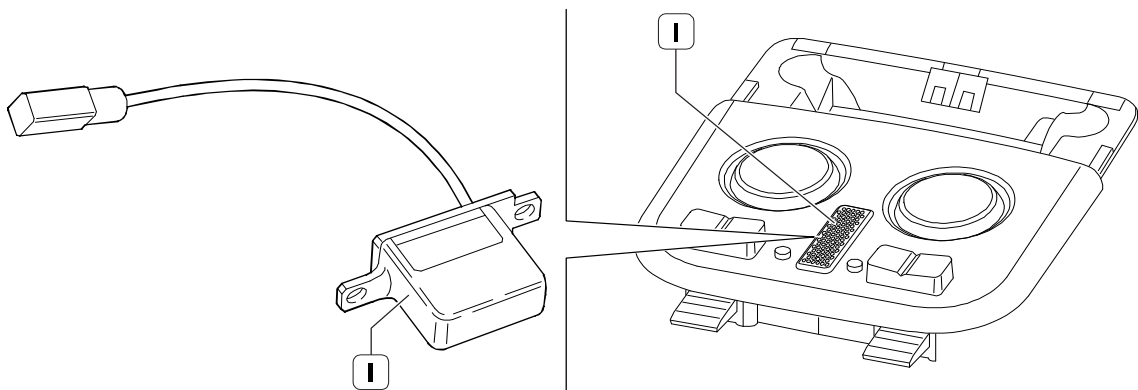

208947 **Figure 33**

1. Bluetooth microphone

Table 5.8

Pin	Description	Cable
1	Ground	White
2	Signal + Vcc	Shielded

The connector of the microphone connection, on the cab wiring side, is located in correspondence with the ceiling connectors.

GPS reception and satellite navigation equipment

Install the transmitting part in a flat, dry area, separate from the electronic components of the vehicle, away from humidity and vibrations. If the transmission is impulsive it must be at a distance of at least one meter away from other devices.

The GPS antenna must be installed so as to have the maximum visibility possible of the sky.

In fact, as the signals received from the satellite are at very low power (approximately 136 dBm), almost any obstacle can influence the quality and performance of the receiver.

The following should therefore be guaranteed:

- an absolute minimum angle of vision of the sky of 90°
- a distance no less than 30 cm from any other antenna
- a horizontal position and never underneath any metal which makes up part of the cab structure.

Moreover:

- the ROS value (Stationary Wave Ratio) must be as close as possible to the unit (the recommended value is 1.5), while the maximum must never be greater than 2 in the GPS frequency range (1575.42 ± 1.023 MHz).
- the ANTENNA GAIN values must be as high as possible and guarantee a sufficient level of spatial uniformity, characterised by deviations in relation to the average value to the order of 1.5 dB in the 1575.42 ± 1.023 MHz band.

Radio installation

Refer to the information contained in the Use and Maintenance Manual

Additional equipment

Power for the equipment, when the voltage required is different to that for the system, must be obtained using a suitable DC/DC 12-24V converter if not already provided. The power cables must be as short as possible, avoiding any twists (coils) and maintaining the minimum distance from the reference plane.

Note *If devices are fitted which could interact with the electronic systems already present (retarders, additional heaters, power take-offs, air conditioners, automatic gearboxes, telematics and speed limiters) please contact IVECO in order to establish the compatibility checks.*



- ▶ **The use of non approved transmitters or supplementary amplifiers could seriously impede the correct functioning of the electrical/electronic devices normally supplied, with negative effects for the safety of the vehicle and/or the driver.**



- ▶ **Any damage caused by the use of non-certified transceivers or by the application of additional amplifiers is not covered by the warranty.**

The vehicle system is set up to supply the necessary power to the equipment provided, for each of which, as part of their function, the specific protection is assured as well as the correct sizing of cables.

The installation of additional equipment must include suitable protections and should not overload the vehicle system.

The connection of the added users to ground must be made with an adequately sectioned cable, as short as possible and made to allow for any movements of the added equipment with respect to the chassis of the vehicle.

Having the need for higher capacity batteries, due to added loads, it is appropriate to request the optional with increased batteries and alternators.

In any case, when increasing battery capacity, it is advisable not to exceed 20-30% of the maximum values provided as optional by IVECO, so as not to damage some of the components (e.g. starter motor). When higher capacities are necessary, use additional batteries, making the necessary provisions for recharging as indicated below.

Additional batteries

The addition of a battery in the vehicle electrical system requires the provision of a circuit that, during start-up, makes it possible to section this battery with respect to the original. Given the new "smart" recharge strategies, the auxiliary battery must be equivalent to the originally installed battery and must have the same capacity (110 Ah).

In cases where it is necessary to use an additional battery in parallel with the series, we recommend the use of a larger alternator or the installation of an extra alternator.

The batteries can be traditional or "recombination" (AGM or gel).

Due to the normal chemical reaction that generates acid vapours during charging, installation must be performed in a way that ensures the safety of people and the protection of the vehicle.

Therefore, regardless of the type of battery, if you do not already have a segregated compartment, it is necessary to:

a) provide an airtight container corresponding to the passenger compartment, equipped with a system that vents vapours to the outside of the vehicle,

or

b) use a battery equipped with a lid with a vapour extraction system, anti-backfire (flame arrestor) system and a vent tube to the outside of the housing.

Also bear in mind that:

- vent systems should not cause depression inside the battery;
- the vapour release point must not be in areas where sparks can be triggered or near heat sources;
- the maximum allowable temperatures, for a short period of time, are 50°C for conventional batteries and 40°C for AGM or gel batteries.



► **Ground connection of the additional battery must be made using a cable (the shortest possible) of adequate section.**

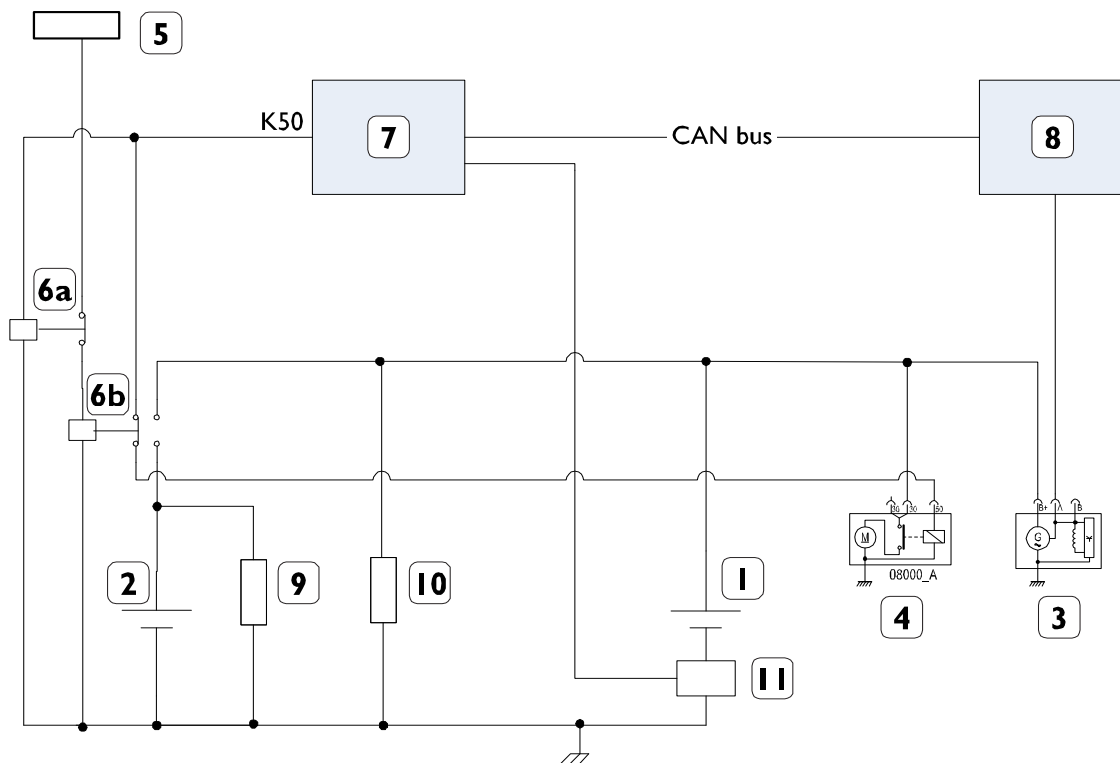

208936

Figure 34

- | | |
|---------------------------------------|-----------------------------------|
| 1. Standard battery | 7. Body Computer |
| 2. Additional batteries | 8. Engine Management control unit |
| 3. Alternator with built-in regulator | 9. Auxiliary load |
| 4. Starter motor | 10. Vehicle load |
| 5. Ignition switch | 11. LIN bus |
| 6. Contactor switches | |



- **All the lines downstream of all batteries are to be adequately protected, under any fault condition. Failure to ensure adequate protection may pose a fire hazard and a danger to persons.**

Additional alternators

The NEW DAILY 4x4 is equipped with an advanced “smart” alternator controlled by the engine ECU.

This alternator is capable of delivering electrical current only when it is really necessary, and is able to always guarantee a correct state of battery charge through the sensor on the negative pole.

In cases where there are very onerous electrical loads a second alternator may be used, and it must be installed (with all the mechanical requirements necessary for compatibility with the vehicle and under the responsibility of the bodybuilder) according to the diagram in Figure 35.

The additional alternator must be of the traditional type, with pin L connected in order to ensure excitation with a current between 150 and 200 mA. The diagnostic light is optional, but a resistance is still necessary to ensure excitation.

Dual alternator operation requires that the additional traditional alternator is the one that delivers in any condition (as it is not controlled), while the original “smart” alternator intervenes when the electrical balance becomes negative (the battery charge status is monitored)

The diagnosis of the two alternators is ensured by:

- a battery indicator on the instrument panel, with regard to the first alternator
- an external diagnostic light (if installed) for the additional alternator

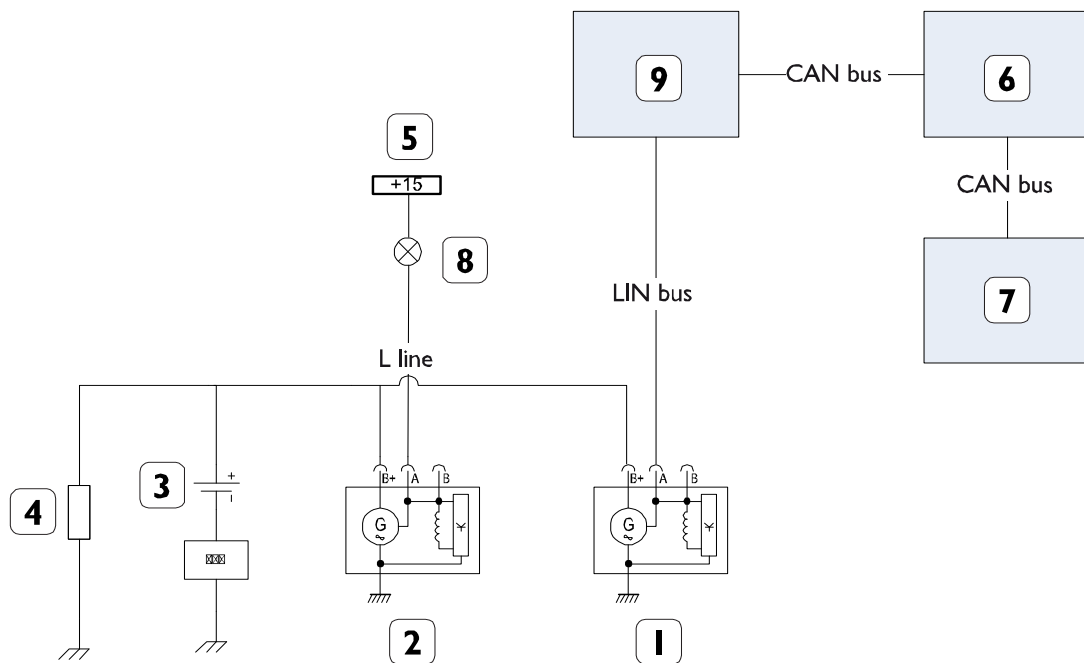

208950 **Figure 35**

- 1. "Smart" first use alternator
- 2. Additional standard alternator
- 3. Battery
- 4. Electrical loads
- 5. Signal +15 from ignition switch

- 6. Body Computer
- 7. Instrument panel
- 8. Diagnostics Lamp or LED +Res. (current between 150 and 200 mA)
- 9. Engine Management control unit

The installation of additional equipment must include suitable protections and should not overload the vehicle system.

The additional alternators must be the type with Zener diode rectifiers to avoid damaging electric/electronic equipment due to accidental battery disengagement. Each alternator must also have a light or LED indicating low battery charge.

The additional alternator must have electrical features identical to those of the standard alternator and the cables must be correctly sized.

If you need to modify the system in a way other than described in this manual (for example, adding batteries in parallel), it is necessary to share the operation with IVECO.

Drawing current

Information about the points where you can take samples of available current and directions to be followed are below.

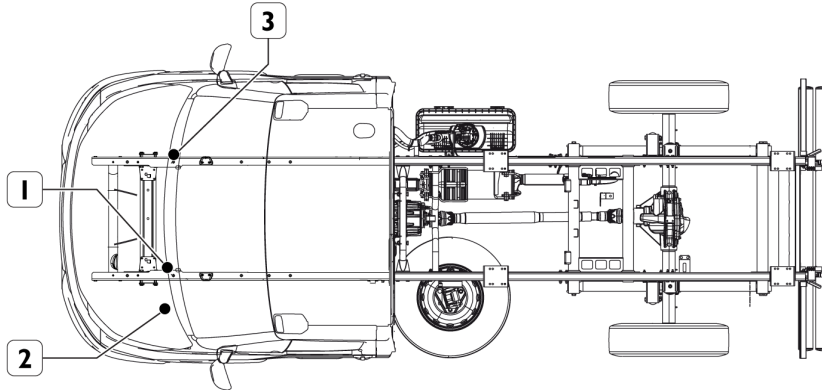

228307

Figure 36

1. CBA2
2. Cable path between cab and engine compartment
3. Body builders Connector (inside cab)

Current sample from the CBA2 control unit in the engine compartment

There are two fuses (FF and FG) installed in CBA2, reserved for the body builders; the terminals **(HI)** and **(MI)** downstream of these fuses are the only two points reserved and authorised for sampling currents.

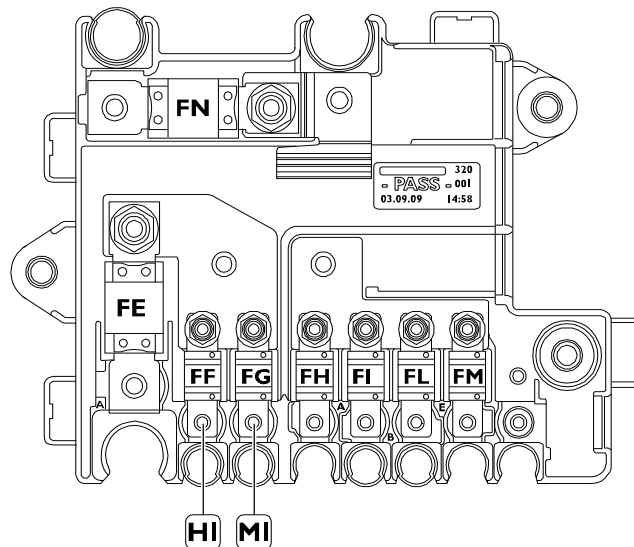

209810

Figure 37

- HI. Current take off point protected by Body builders fuse FF
- MI. Current take off point protected by Body builders fuse FG

The fuses for body builders supplied with the original equipment have a capacity of 30 A each.

If necessary they can be replaced with ones of a higher load respecting the indication of a maximum total withdrawal (sum of the two fuses) equal to 130 A.

Precautions

In general it is advisable to:

- adopt, where necessary, adequate protection fuses applied in the vicinity of the sample;
- protect cables inserted into the proper sheathing or corrugated cables, installing according to the recommendations in Chapter 5.4 (► Page 20) - Paragraph: "Precautions for operations on the system".

And in CBA2 installation it is necessary to:

- avoid removing the fuses from their position;
- put the terminals on the studs and secure them with the nuts (M5 flanged nut, self-locking, etc.), tightening to torque (4 to 6 Nm);



► **It is absolutely forbidden to draw current from unauthorised points. FIRE HAZARD.**

Fuses on CBA1 control unit on battery

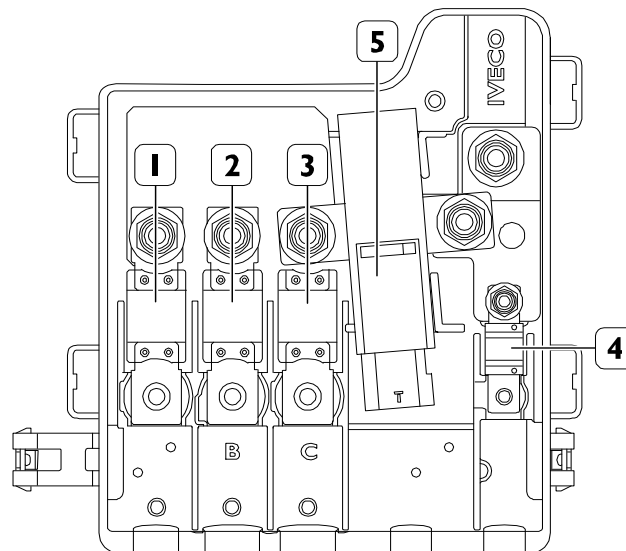

208221 **Figure 38**

Table 5.9 - List of fuses on CBA1

Location	Amperage [A]	Description
1	150	Power supply CBA2
2	200	Power supply SCM and Body builders
3	500	Starter and Retarder
4	80	Body Computer power supply
5		TGC (opt)

Fuses on CBA2 control unit in the engine compartment

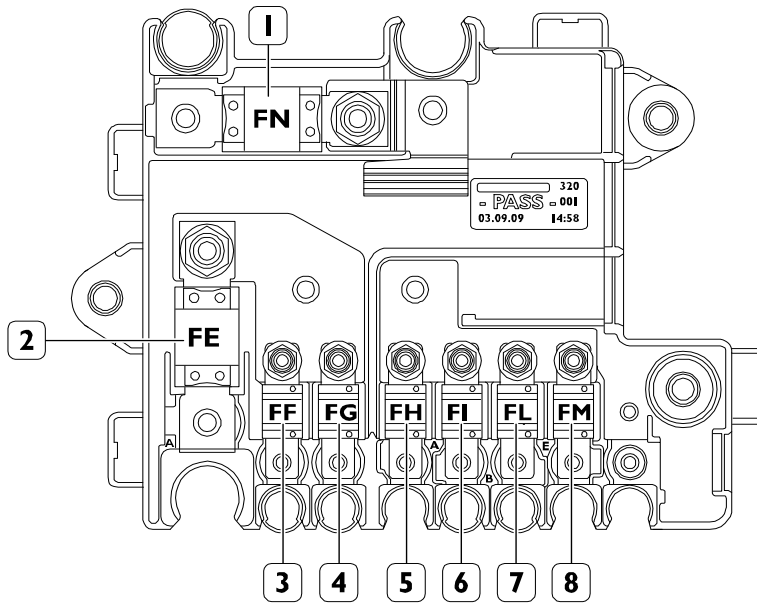

209812

Figure 39

Table 5.10 - List of fuses on CBA2

Location	Amperage [A]	Description
1	150	Retarder
2	150	SCM Power supply
3	30	Body builders pre-installation
4	30	Body builders pre-installation
5	60	Pre- / post- heating unit
6	30	Urea module
7	100	PTC power supply
8	40	ABS

Passage of cables from cab interior to cab exterior

In the engine compartment, close to the servo brake, through the five premade 10 mm holes in the bulkhead, it is possible to pass the electric cables from the cab to the engine compartment. Adequately seal the cable passage area to avoid passing fumes from the engine compartment to the cab.

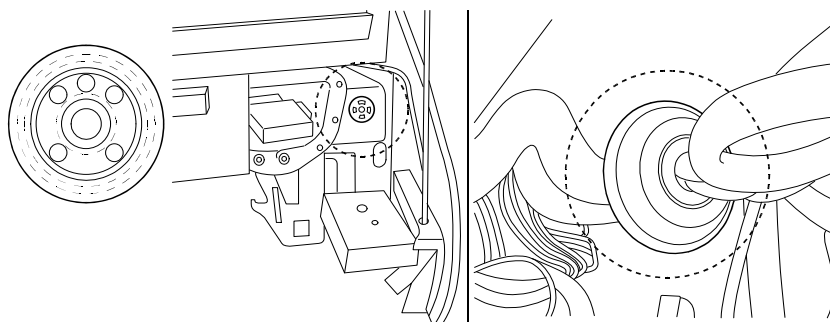

119355

Figure 40



► **Any damage caused by failure to comply with procedure is not covered by warranty.**

Additional circuits

The additional circuits must be separated from the vehicle and protected by means of a specific fuse

As already seen in the Paragraph "Precautions for work on the system", the used cables must be:

- of appropriate sizes and equipped with good original insulation;
- connected to the original system by means of tin joints equivalent to the original ones, protected with sheaths (not PVC) or intubated in polyamide conduits of type 6;
- installed protections from shock, heat, rubbing with other components (in particular with the sharp edges of the bodywork);
- secured separately with insulated cable clamps (e.g. nylon) and at suitable intervals (approx. 200 mm).

The passage through crossbars and/or sections must provide special fairleads or protections; it is not possible to drill the chassis and/or the bodywork.

In case of external panels, use a specific sealant both on the cable and on the panel to prevent water, dust and fumes from infiltrating.

Where possible it shall also be provided a different cable path that transfers interference signals with high absorbed intensity (e.g. electric motor, solenoid valves) and low absorbed intensity susceptible signals (e.g. sensors); for both must be remained a positioning as close as possible to the metallic structure of the vehicle.

Plug and terminal connections must be protected, resistant to weathering, and executed using components of the same type as those utilised originally on the vehicle.

Use cables and fuses with the characteristics shown in the following table in accordance with the current draw:

Table 5.11 - Use of cables and fuses according to the current drawn

Max. continuous current ⁽¹⁾ [A]	Cable cross-section [mm ²]	Fuse capacity ⁽²⁾ [A]
0 ÷ 4	0.5	5
4 - 8	1	10
8 ÷ 16	2.5	20
16 - 25	4	30
25 - 33	6	40
33 ÷ 40	10	50
40 - 60	16	70
60 - 80	25	100

Max. continuous current ⁽¹⁾ [A]	Cable cross-section [mm ²]	Fuse capacity ⁽²⁾ [A]
80 ÷ 100	35	125
100 - 140	50	150

⁽¹⁾ For uses of more than 30 seconds.

⁽²⁾ Depending on the position and therefore the temperature that may be reached in the housing, choose fuses that can be loaded to up to 70%- 80% of their maximum capacity.



► **The fuse must be connected as close as possible to the current take-off point.**

Precautions

- Incorrect installation of electrical accessories may affect occupant safety and cause severe damage to the vehicle. Contact IVECO if you have any questions.
- It is necessary to avoid coupling with the signal transmission cables (eg. ABS), for which preferential routing has been provided in order to meet electromagnetic requirements (EMI).
It should be noted that when grouping several cables together, in order to compensate for lower heat dispersal capacity, the current intensity must be reduced with respect to the nominal value of a single cable.
- In vehicles with frequent engine start-ups, with limited current drawn and engine rotations (e.g. vehicles with refrigeration chambers), provide for periodic battery charging to maintain efficiency.
- Plug and terminal connections must be protected, resistant to weathering, and executed using components of the same type as those utilised originally on the vehicle.
- In the event that a component has to be installed just next to the route of a cable belonging to the original system, make sure that its remains integral and avoid any cuts.

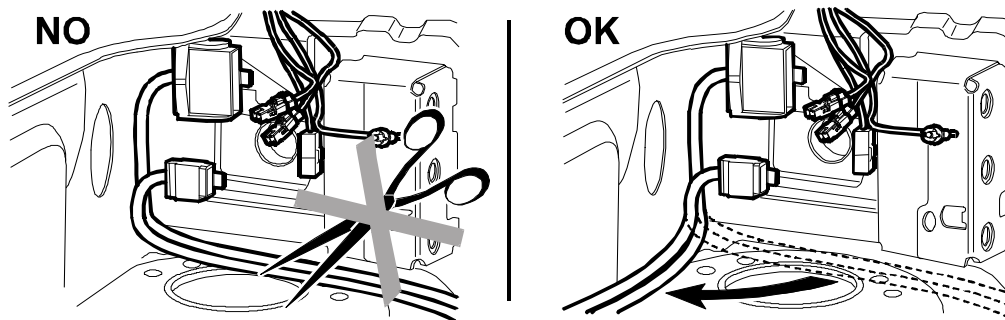

209813

Figure 41



► **Any damage caused by failure to comply with procedure is not covered by warranty.**

Modifying wheelbase and overhang

Should it be necessary to lengthen the wires on the chassis owing to the new dimensions of wheelbase and overhang, a watertight junction box must be used which has the same characteristics as those used on the standard vehicle. The electrical components used such as wires, connectors, terminal blocks, conduits etc. must be of the same type as those used originally and must be correctly fitted.

As for the functionality of the electronic control devices, junctions are not permitted: the cable must be replaced with a new one with similar characteristics to the one used on the vehicle and of adequate length.

Trailer setup

If the repetition of rear lights is necessary, the vehicle must be fitted with the 13-pin trailer socket.

Do not hook up directly to the vehicle's light cables. This results in current overloads which are recognised as malfunctions by the on-board computer.

If the vehicle is not equipped with a trailer socket, it is possible to order a special kit comprising of:

- control unit with fastening bracket and guard;
- chassis cable with trailer configuration;
- rear bridle for trailer socket.

For proper installation it is necessary to:

- mount the electronic control unit onto the bracket; on the cab version also mount the guard;
- mount the entire bracket plus control unit onto the chassis as shown in Figure 42;
- replace the chassis cable with the new cable configured for the trailer socket (see Figure 43);
- fit the connection bridle for the 13-pin socket compatible with the type of hook (high or low) (see Figure 44).

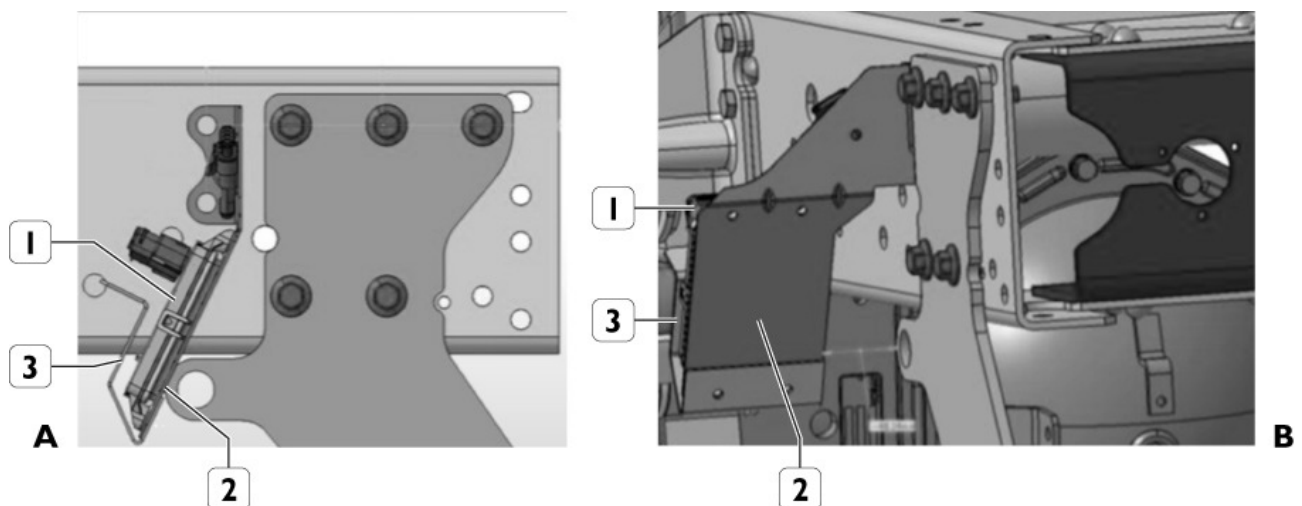

209814

Figure 42

- A. Side view
B. Rear view

1. Trailer electronic control unit
2. Support bracket
3. Guard

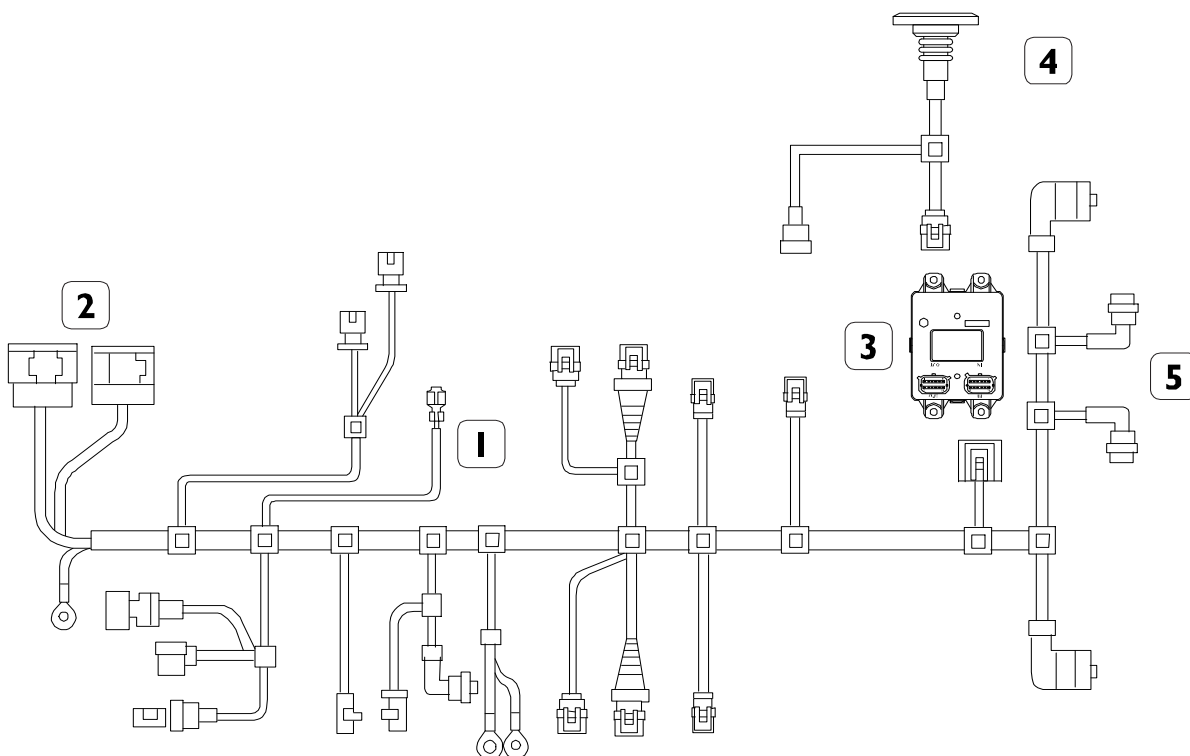

209816

Figure 43

Chassis cable with 13 pin socket and trailer control unit

- | | |
|------------------------------------|--------------------------|
| 1. Chassis cable | 4. 13-pin trailer socket |
| 2. Connections with cab wiring | 5. Tail lights |
| 3. Trailer electronic control unit | |

Note The graphic is for illustration purposes only.

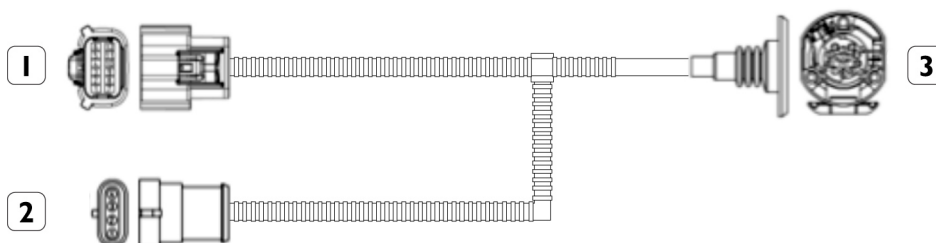

209815

Figure 44

- | | |
|--|--|
| 1. Connector 86046_1 to connect to connector 1 (OUT) of trailer control unit | 2. Connector ST63 to connect to chassis wiring |
| | 3. 13-pin trailer socket 72016 |

For further details on connections and installation, request wiring diagrams from IVECO.



- **Any damage to the light system caused by failure to comply with procedure is not covered by warranty.**

Table 5.12 - 13-pin trailer socket

Pin	Description	Cable code	Remarks
1	Rear left turn indicator	1120	1 21 W- 12 V lamp
2	Rear fog lamp power supply	2283	2 21W - 12V lamps
3	Ground	0000	–
4	Rear right turn indicator	1125	1 21 W- 12 V lamp
5	Front left and rear right parking light Left license plate light and left side marker light	3335	3 5 W - 12V lamps
6	Stop signal lights power supply	1175	2 21W - 12V lamps
7	Front right and rear left parking light. Right license plate light and right side marker light	3334	3 5 W - 12V lamps
8	Power supply for reverse light	2268	2 21W - 12V lamps
9	After fuse F67 present on SCM1/B	7777	Battery positive
10	After fuse F49 present on Body Computer	8879	Positive with key
11	Ground	0000	–
12	Trailer connection signal (Ground)	6676	1. Signal to be supplied through connection on the trailer, to permit trailer lights and parking sensor diagnostics (if present) 2. Pin 12 could be absent as it may have been replaced by a switch integrated in the socket; in this case it is not necessary to perform any connection on the trailer
13	Ground	0000	–



- ▶ **The electrical connection of a trailer entails a considerable increase in the length of the cables and results in a larger voltage drop on the line. Therefore the use of cables with the biggest possible cross-section is recommended, which are compatible with the system layout and with the 13-pin socket; on this it is then necessary to divide the ground return by using all three pins 3, 11 and 13.**

Side Marker Lamp installation

The installation of the lateral lights must be performed on the additional structures (containers, vans, etc.), while the electric power supply must be obtained by the specific ST38 connector on the chassis (see Figure 45).

In order to keep the electrical characteristics of the contacts of the female socket unchanged, the hood supplied by IVECO must be left attached.



- ▶ **It is not possible to draw current from side marker lights.**

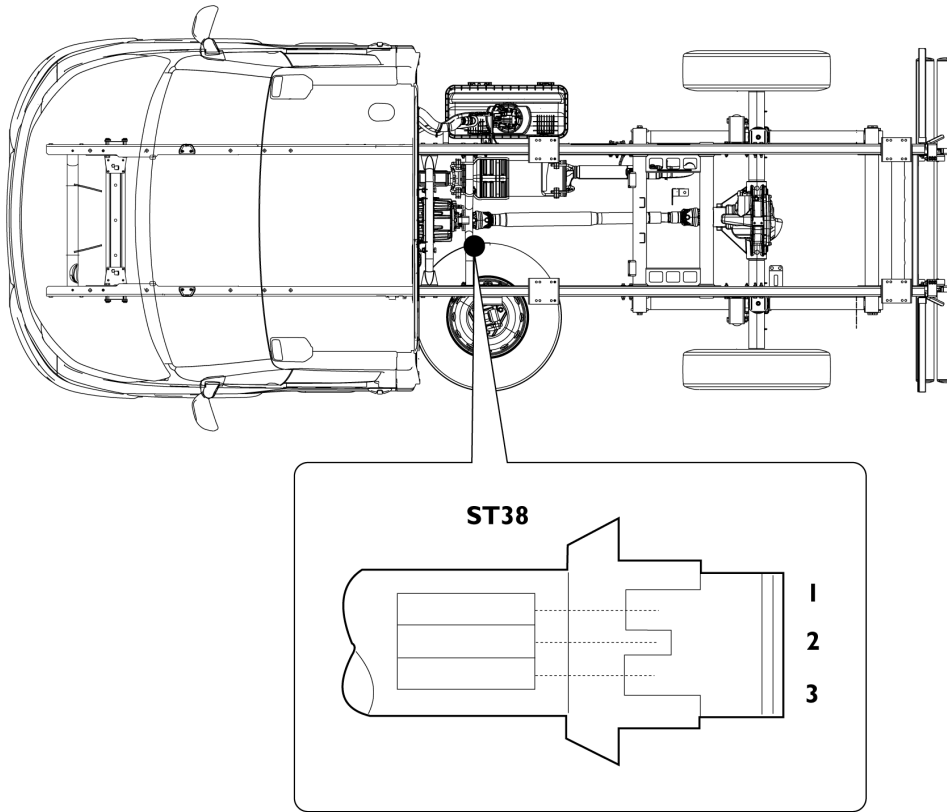

228308

Figure 45

Table 5.13 - Connector ST38 for Side Marker Lamps

Pin	Description	Cable code	Max. current [A]	Connected to	Remarks
1	Ground	0000	10	ST43/1	Ground for left and right side clearance lights
2	Vehicle left side clearance lights	3390	10	ST43/2	+12 V = vehicle left side clearance lights on no signal = vehicle left side clearance lights off
3	Vehicle right side clearance lights	3390	10	ST43/2	+12 V = vehicle right side clearance lights on no signal = vehicle right side clearance lights off

Installation of side markers requires the intervention of the IVECO Service Network in order to enable the Body Computer.

Reverse gear signal

For safety reasons, certain vehicle versions must emit an external reversing warning sound which is activated when the vehicle is reversing.

This safety device may be originally requested as opt. 7638.

In the event of a subsequent or alternative realization, its application is recommended inside the rear cross member of the number plate holder, as in Figure 46.

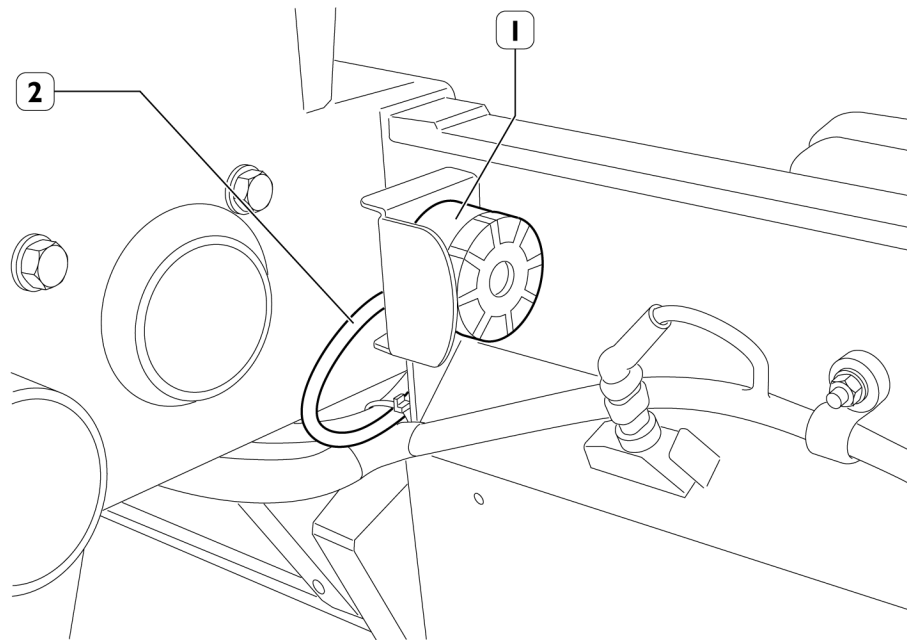

230824 **Figure 46**

1. Reverse buzzer

2. Reverse gear signal cable

This device is operated by a two terminal connector with safety cap.

Table 5.14 - Connector for reverse gear signal

Pin	Description	Cable code	Max. current [mA]	Connected to	Remarks
1	Reverse	2226	100 ⁽¹⁾	BCM/F01	Signal logic: in parallel with the reversing lights +12 V = reverse gear engaged no signal = reverse gear not engaged Add a protection diode
2	Ground	0000	100		Ground for reverse gear

⁽¹⁾ With reverse gear warning sound indicator IVECO (opt. 7638) the maximum current is limited to 70 mA.

Antitheft system

In combination with the central locking, the vehicle can be equipped with an alarm system controlled by the Body Computer and a peripheral system.

This system consists of:

- a key with remote control, buttons for distance locking/unlocking;
- actuators for closing the cab doors and sliding side doors in the case of a van;
- open door sensors and engine bonnet opening perimeter sensor (Figure 48 left);
- alarm siren (12 V) (Figure 48 right).

The antitheft current absorption is 30-40 mA.

The body builder must provide a "closed door" signal so that the antitheft system can also detect engine bonnet break-ins.

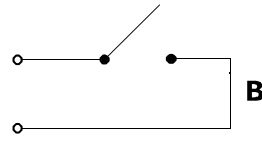
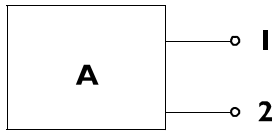

208227

Figure 47

Engine bonnet button connection diagram ⁽²⁾

- A. Engine bonnet socket
- B. Body builder button switch

- 1. Pin 1: door closed signal
- 2. Pin 2: door closed signal

⁽²⁾ Only for versions with reduced cowl, cowl, reduced cowl for camper with opt 5865

Open circuit → when the door is closed

Closed circuit → when the door is open

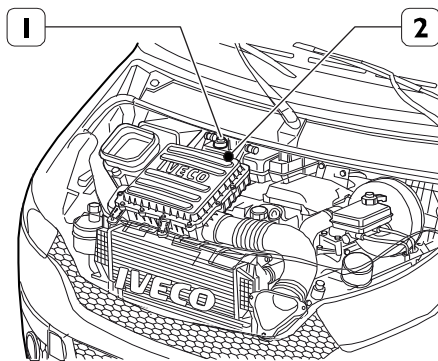

- 1. Bonnet open sensor
- 2. Engine bonnet socket

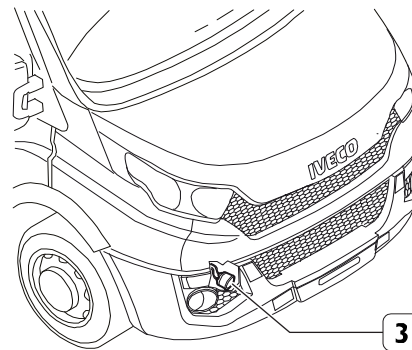

208229

Figure 48

- 3. Alarm siren

For the operation mode refer to the Use and Maintenance Manual.

SECTION 6
**ADBLUE AND
SCRT SYSTEM**

Contents

6.1	GENERAL INFORMATION	5
6.2	THE NITROGEN OXIDE CATALYTIC REDUCTION PRINCIPLE	5
6.3	INSTRUCTIONS	5
	Materials	6
	AdBlue tank	6
6.4	MOVING ADBLUE SYSTEM COMPONENTS	7

ADBLUE AND SCRT SYSTEM

6.1 GENERAL INFORMATION

To comply with Euro VI requirements on engine gas emissions, IVECO has developed the "SCRT" (Selective Catalytic Reduction Technology) system, consisting of the combined action of a diesel particulate filter (DPF) and post-treatment of exhaust gas (SCR). This post-treatment requires the use of an additive, commercially known as AdBlue (urea solution+water).

6.2 THE NITROGEN OXIDE CATALYTIC REDUCTION PRINCIPLE

The additive AdBlue, is sent from a dedicated tank by means of a SM (Supply Module) pumping module to a DM (Dosing Module) which injects AdBlue into the exhaust pipe. The mixture of exhaust gas and additive is then fed into the catalytic converter and chemically transforms NO_x into nitrogen and water, which are harmless to the environment.

Main components of SCRT system

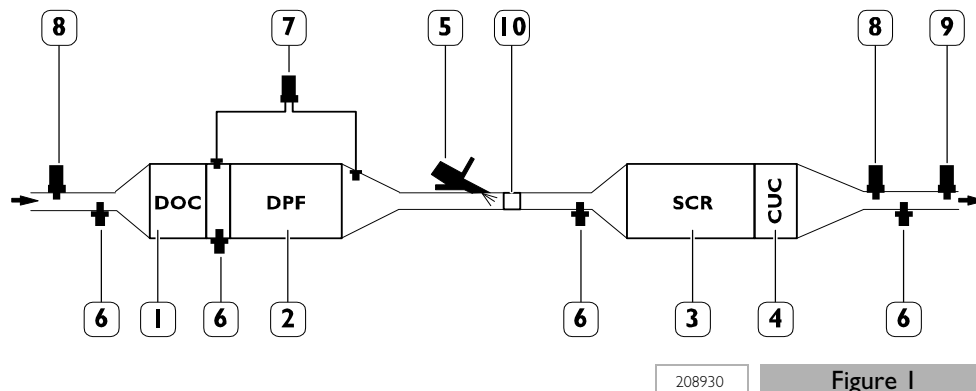

- | | |
|----------------------------------|---------------------------|
| 1. Diesel Oxidation Catalyst | 6. Temperature sensors |
| 2. Diesel Particulate Filter | 7. DPF Δp sensors |
| 3. Selective Catalytic Reduction | 8. NO_x sensors |
| 4. Clean Up Catalyst | 9. NH_3 Sensor |
| 5. Dosing Module | 10. Mixer |

DOC : to oxidise the exhaust gas components through the use of oxygen.

DPF : to eliminate the particulate before SCR through passive regeneration.

SCR : to reduce the NO_x through the injection of AdBlue.

CUC : to eliminate the ammonia residues (NH_3).

6.3 INSTRUCTIONS

The following instructions are intended for the AdBlue injection system of the Bosch De NO_x 3.1 type.

Note *The materials and layouts of normal IVECO production are specifically approved; all other circumstances of variation must be specifically authorized.*

If changes are made to the chassis which involve this system, the following procedure must be followed under all circumstances:

- all post-treatment components must be installed under extremely clean conditions;
- the protection caps of the SM, DM and the AdBlue pipe bundle may only be removed just before assembly;

- the SM and DM fittings must be handled with care;
- the SM and DM fastening screws must be tightened to the torque specified in the relevant assembly diagrams;
- the seal of the DM flange on the ATS side must be replaced each time the DM is disassembled (the seal may only be used once);
- the “after-run” phase must not be interrupted using the battery manual switch or the ADR switch (the AdBlue pipes must always be emptied to prevent any crystallization or damage from freezing);

Materials

The AdBlue solution may be corrosive for ferrous steels and, in turn, may be contaminated by additives used for moulding plastic materials. Therefore any parts of specific form may only be realized upon IVECO approval and only with the following materials:

- Molybdenum austenitic chromium-nickel steel in compliance with DIN EN 10088
- Polyethylene HD
- Polypropylene HD
- Polyfluoroethelene
- Polyvinylidene fluoride
- Perfluoroalkoxy
- Polyisobutylene
- Titanium
- Viton

AdBlue tank



▶ **No modifications to the original tank are permitted.**

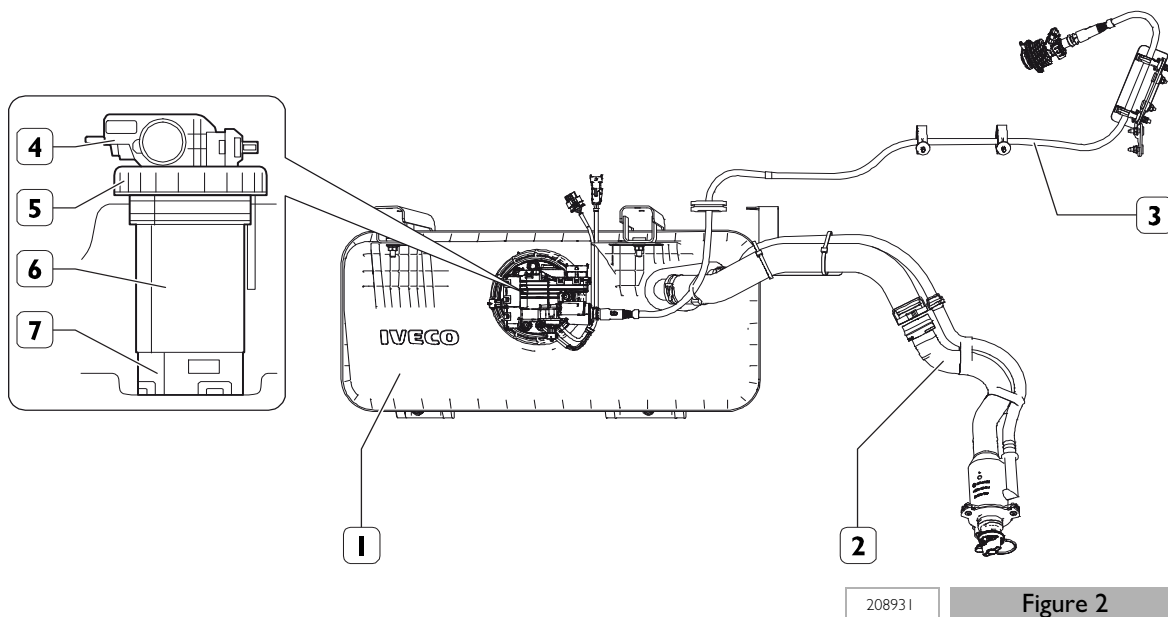

208931

Figure 2

- | | |
|--|--|
| 1. AdBlue tank | 5. Fastening ring nut |
| 2. AdBlue refuelling filler | 6. Heating pot |
| 3. Heated pipe for AdBlue delivery to dosing module DM | 7. Locking ring welded to tank housing |
| 4. SM Pumping module | |

It should be noted that:

- The tanks must be equipped with fittings for bleeding and with a fitting for adding the AdBlue; the connections between the tank fittings and the inlet must be airtight.
- The tank must be positioned at a minimum height of 200 mm from the ground for an unloaded vehicle and in any case at a height equal to or greater than the lowest wire of the exhaust system.
- The tank is secured to the chassis with specific brackets; any modifications must be authorized by IVECO.
- The Heating Pot unit (6) / Supply Module (4) / Tank (1) may only be disassembled by IVECO Authorized Workshops and must be repositioned according to the approved layout of normal production; any modifications must be authorized.
- The hydraulic connections must comply with Standard SAE_J2044 ¼.
- To ensure the seal of the SM pumping module on the tank, the ring nut tightening torque must be 85 Nm.

At the end of any operations which involve the AdBlue tank, make sure that:

- the tank ventilation pipe is not closed or restricted;
- the tank contains at least 4 litres of AdBlue to ensure the dosing module is cooled;
- the tank does not contain more than 85% of AdBlue (corresponding to the maximum reading of the level sensor) with respect to the tank total volume, so as to guarantee enough room for AdBlue to expand during freezing at temperatures below -11 °C.

AdBlue refuelling filler

The filler assembly consists of:

- a filler with a specific plug for AdBlue filler nozzles, a filter and a magnet for opening the nozzle valve;
- a pipe connecting the filler to the tank breather.

Note *If the filler door on the bodywork is modified, the original accessibility to the underlying plug must be maintained.*

The following points are mandatory since AdBlue crystallises at -11 °C:

- ensure the pipes are at an incline which prevents urea from accumulating (syphons) inside;
- respect the original incline of the filler in relation to the ground.

6.4 MOVING ADBLUE SYSTEM COMPONENTS

Note *Modifications to the positions of the AdBlue system components are strongly discouraged and, in any case, must be specifically authorized by IVECO.*

Therefore please note that:

- a) the original position of the dosing module DM on the exhaust pipe must never be modified;
- b) any repositioning of the AdBlue tank must correspond to the installation heights of the already approved SM module;
- c) any new heated pipe (by configuration or length) must be chosen only from those adopted in production;
- d) plastic parts must be at least 200 mm from any heat source (eg. exhaust system); if heat-protecting panels are used this distance can be reduced to 80 mm.

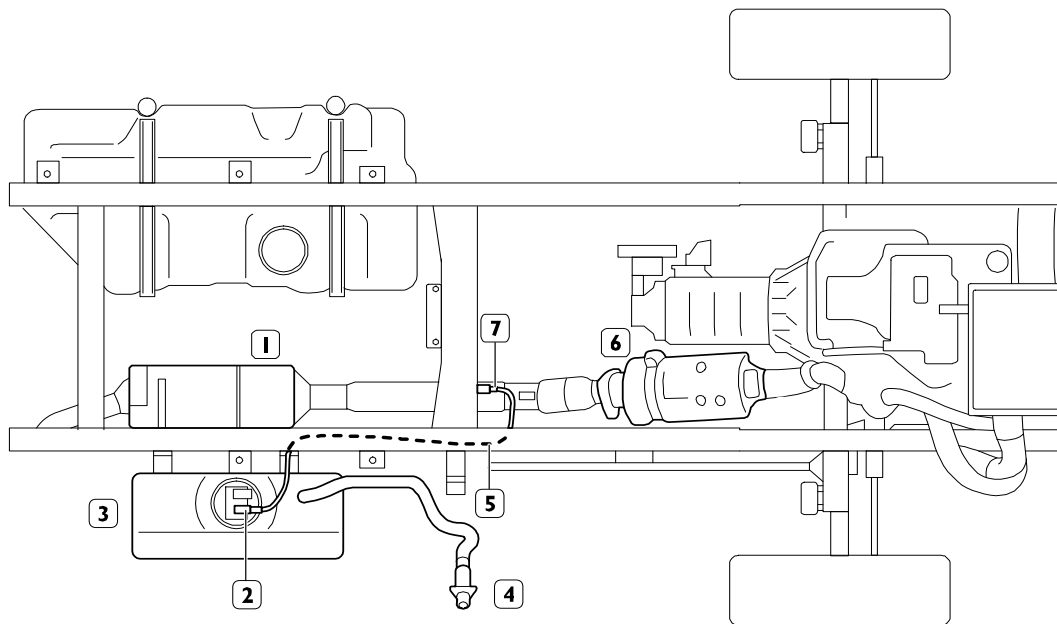

208932

Figure 3

1. SCR catalytic converter
2. Pumping module (SM)
3. AdBlue tank
4. AdBlue refuelling inlet
5. AdBlue delivery pipe
6. DPF Particulate filter
7. Dosing module (DM)